

# Service Manual

SL-D2

Turntable System

## SL-D2

(M), (MC)



- The model SL-D2 (M) is available in America only.
- The model SL-D2 (MC) is available in Canada only.

**Specifications** Specifications are subject to change without notice.  
Weights and dimensions shown are approximate.

### General

**Power supply:** 120 V, 50 or 60 Hz  
**Power consumption:** 4 W  
**Dimensions:** 43.0 x 13.0 x 37.5 cm  
 (W x H x D) (16-59/64 x 5-7/64 x 14-49/64 inches)  
**Weight:** 6.9 kg (15.2 lb.)

### Turntable section

**Type:** Automatic turntable  
Auto return  
Auto stop  
**Drive method:** Direct drive  
**Motor:** Brushless DC motor  
**Drive control method:** B-FG servo control  
**Turntable platter:** Aluminum die-cast  
**Turntable speeds:** 33-1/3 rpm and 45 rpm  
**Pitch control:** 10% adjustment range  
**Wow and flutter:** 0.014% WRMS (\*)  
0.03% WRMS (JIS C5521)  
±0.042% peak (IEC 98A Weighted)

\* This rating refers to turntable assembly alone, excluding effects of record, cartridge or tonearm, but including platter measured by obtaining signal from frequency generator attached to motor assembly.

**Rumble:** -53 dB (IEC 98A Unweighted)  
-75 dB (IEC 98A Weighted)

### Tonearm section

**Type:** Universal tonearm  
**Effective length:** 230 mm (9-1/16")  
**Overhang:** 15 mm (19/32")  
**Friction:** Less than 7 mg (lateral, vertical)  
**Effective mass:** 12 g (without cartridge)  
**Tracking error angle:** Within 2°32' at the outer groove of 30 cm (12") record  
Within 0°32' at the inner groove of 30 cm (12") record

**Offset angle:** 22°  
**Stylus pressure adjustment range:** 0 - 2.5 g  
**Applicable cartridge weight range:** 6 - 9.5 g  
13.5 - 17 g (including headshell)

**Applicable cartridge weight range:** 3 - 6.5 g  
**(with shellweight)** 10.5 - 14 g (including headshell)  
**Headshell weight:** 7.5 g

## Technics

Panasonic Company  
Division of Matsushita Electric Corporation of America  
One Panasonic Way, Secaucus, New Jersey 07094

Panasonic Hawaii, Inc.  
320 Waiakamilo Road, Honolulu, Hawaii 96817

Matsushita Electric of Canada Ltd.  
5770 Ambler Drive,  
Mississauga, Ontario  
L4W 2T3

## ■ CONTENTS

PARTS IDENTIFICATIONS .....	2
FEATURES .....	2
HOW TO OPERATE .....	3
ADJUSTMENTS .....	4
DISASSEMBLY PROCEDURE .....	5
PARTS ARRANGEMENT DIAGRAM .....	6
BLOCK DIAGRAM .....	7

REPLACEMENT PARTS LIST (Electric Parts) .....	8
SCHEMATIC DIAGRAM .....	9 ~ 10
TERMINAL GUIDE OF TRANSISTORS & IC .....	10
PRINTED CIRCUIT BOARD .....	11 ~ 12
EXPLODED VIEWS .....	13 ~ 15
REPLACEMENT PARTS LIST (Mechanical Parts) .....	16

## ■ PARTS IDENTIFICATIONS

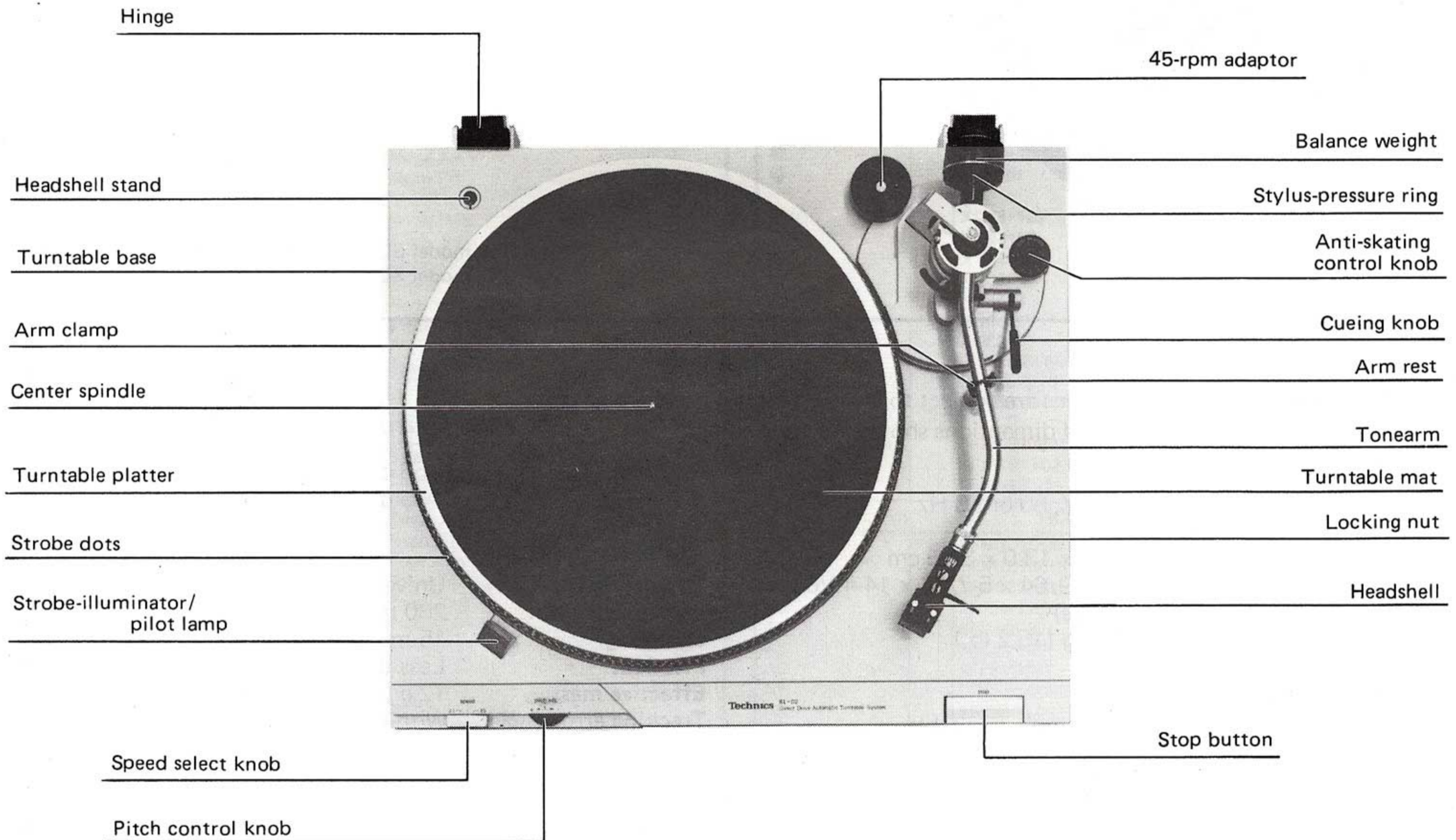

## ■ FEATURES

- Front panel controls provide exceptional convenience
- Integral rotor/platter structure for stable rotation
- "TNRC"\* base material provides an acoustic shield  
"TNRC" . . . . .Technics Non-Resonance Compound
- Low-mass, low-friction gimbal suspension tonearm
- Pitch control with illuminated stroboscope
- Viscous-damped cueing
- Anti-skating control
- Hinged, detachable dust cover
- Automatic tonearm return

## ■ HOW TO OPERATE

1. Place a record on the turntable mat.
2. Set the speed select knob to the desired record speed. (See Fig. 1.)

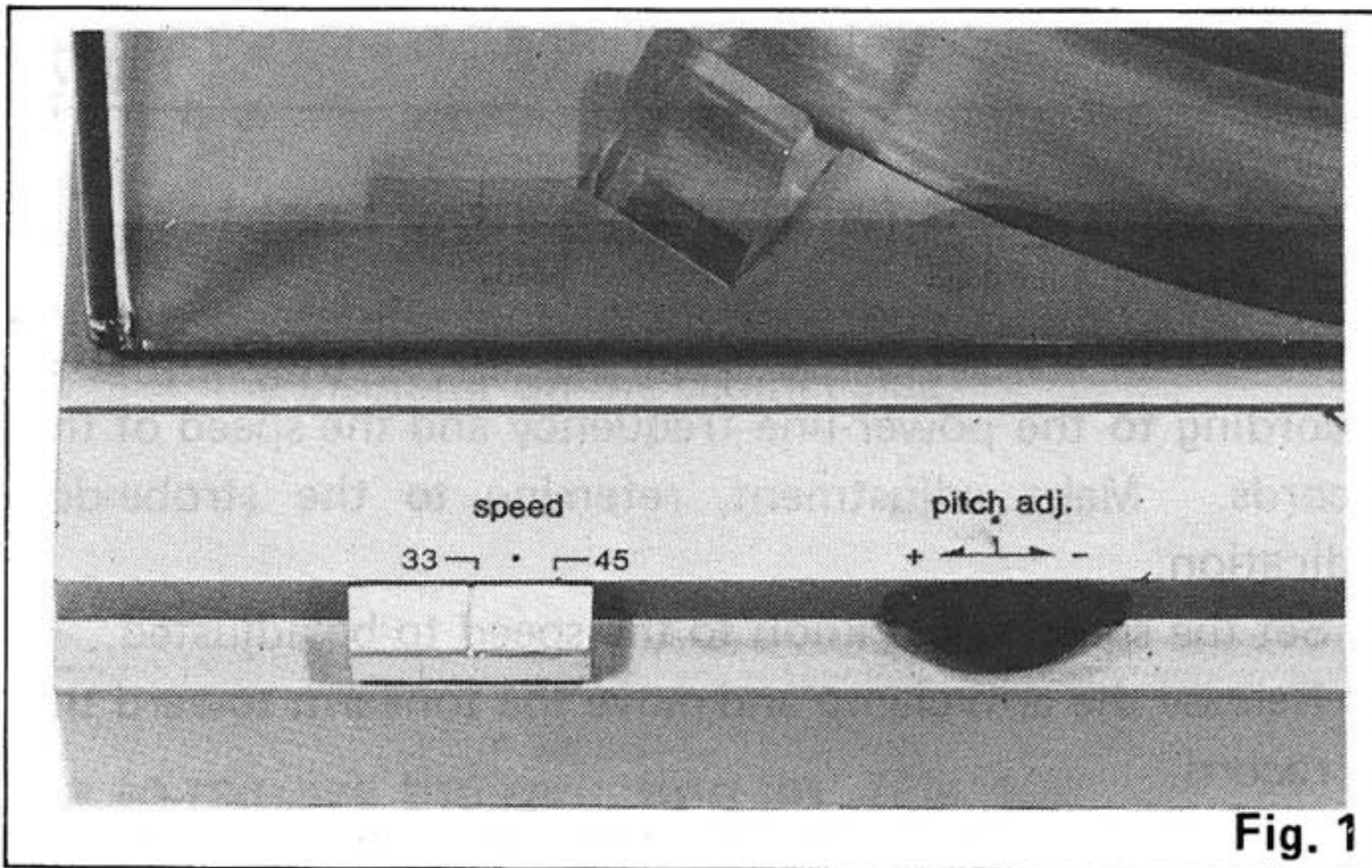

Fig. 1

3. Remove the stylus protector, if your cartridge has a detachable one.
  4. Release the arm clamp.
  5. Set the cueing lever to the "up" position. (See Fig. 2.)
  6. Move the tonearm over the desired groove.
  7. Set the cueing lever to the "down" position. (See Fig. 3.)
- The tonearm will descend slowly onto the record and play will begin.
- When play is finished, the tonearm will automatically return to the arm rest (auto-return), and the turntable platter will stop rotation.

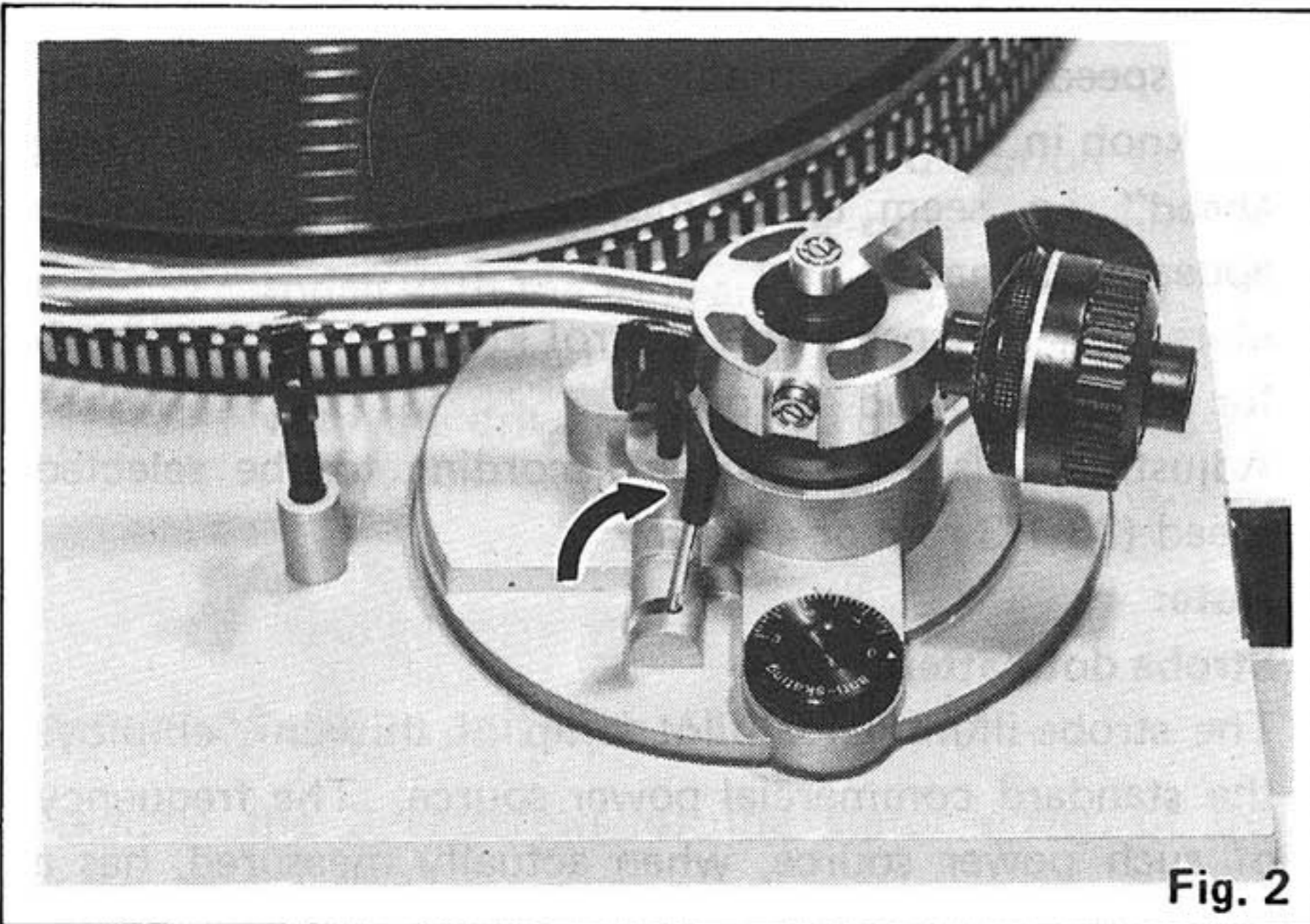

Fig. 2



Fig. 3

### How to stop play

Push the stop button. (See Fig. 4.)

The tonearm automatically returns to the arm rest, and the turntable stops rotating.

Of course, the unit will automatically shut off even when the tonearm is manually returned to its arm rest directly.

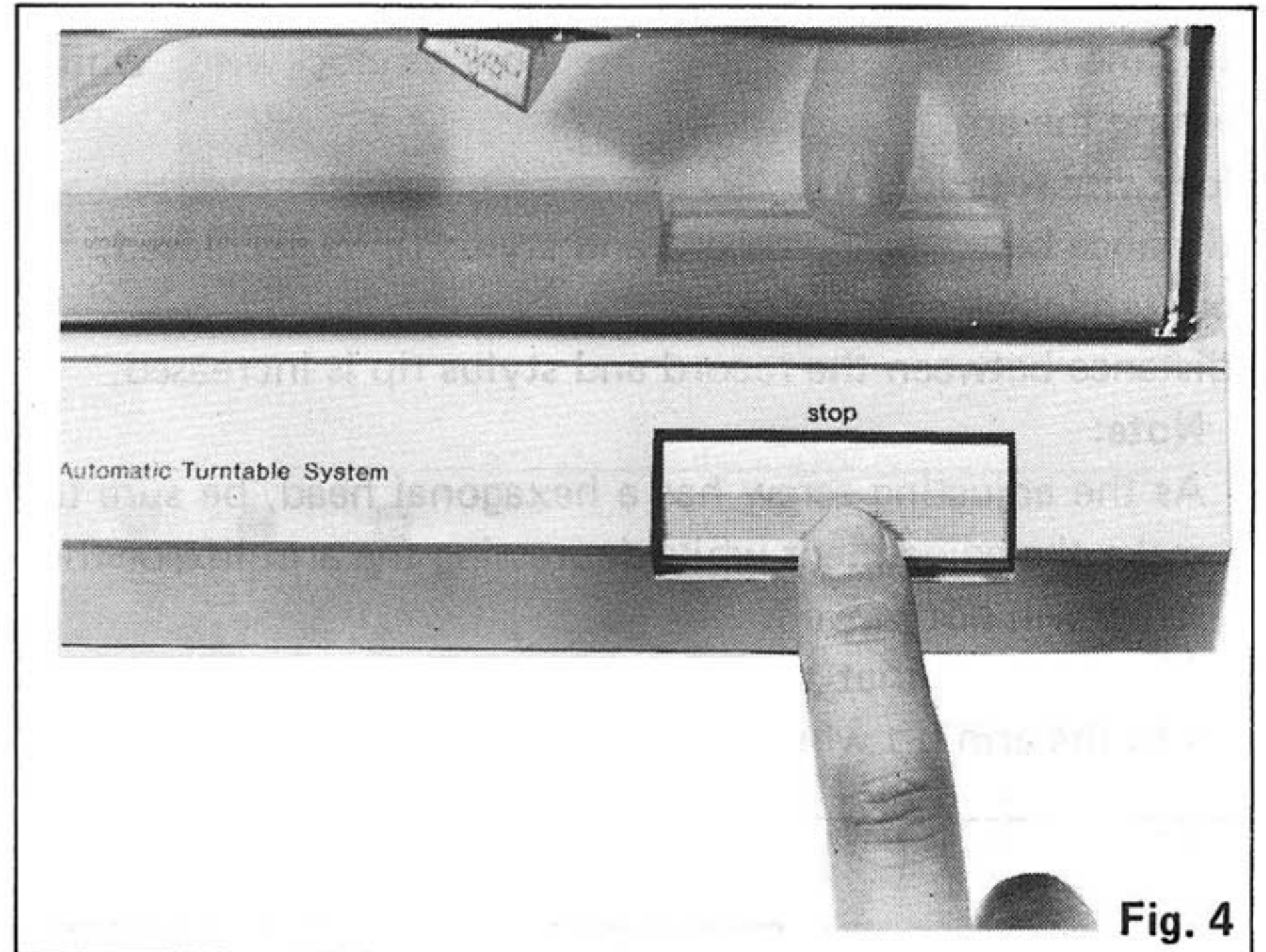

Fig. 4

### How to suspend play

Set the cueing lever to the "up" position.

The stylus tip of the cartridge will be lifted from the record.

### When you play a 45-rpm record with a large center hole

Place the 45-rpm adaptor on the center spindle. Set the speed select knob to the "45" position.

### If the unit is not to be used for some time

Secure the tonearm with the arm clamp.

Attach the stylus protector, if your cartridge has one, to guard the stylus from damage.

Close the dust cover.

### Lubrication (See Fig. 4-1.)

Apply 2 or 3 drops of oil once after every 2000 hours of operation.

The time interval is much longer than that for conventional type motors (200 – 500 hours).

Please purchase original oil. (Part number is SFWO 010.)

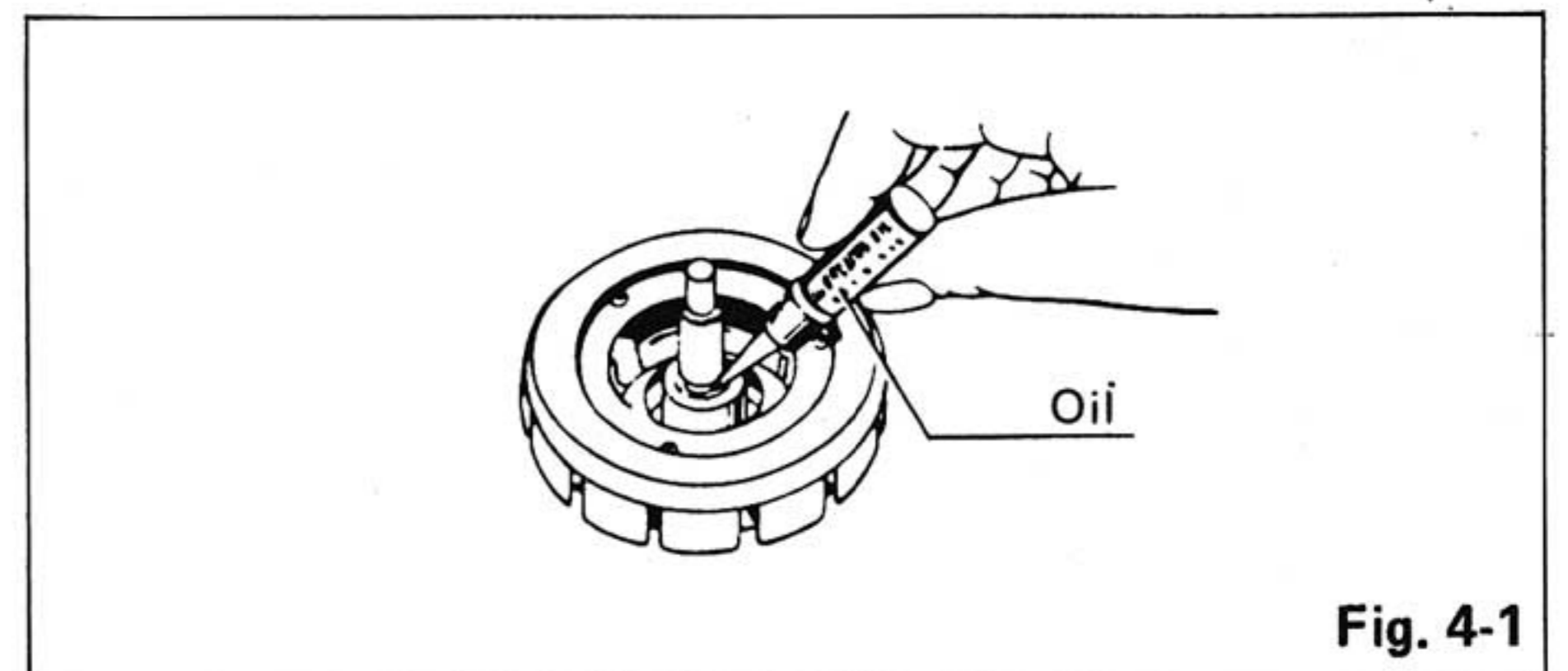

Fig. 4-1

## ■ ADJUSTMENTS

### Adjustment of the arm-lift height

(See Figs. 5 and 6.)

The arm-lift height (distance between the stylus tip and record surface when cueing lever is raised) has been adjusted at the factory before shipping to approximately 5 to 10 mm.

If the clearance becomes too narrow or too wide, turn the adjustment screw clockwise or counterclockwise, while pushing the arm lift down.

#### Clockwise rotation

—distance between the record and stylus tip is decreased.

#### Counterclockwise rotation

—distance between the record and stylus tip is increased.

#### Note:

As the adjusting screw has a hexagonal head, be sure to make the adjustment while depressing the arm lift, or the screw will not move freely.

Also be sure that the hexagonal head retracts correctly into the arm lift when the latter is released.

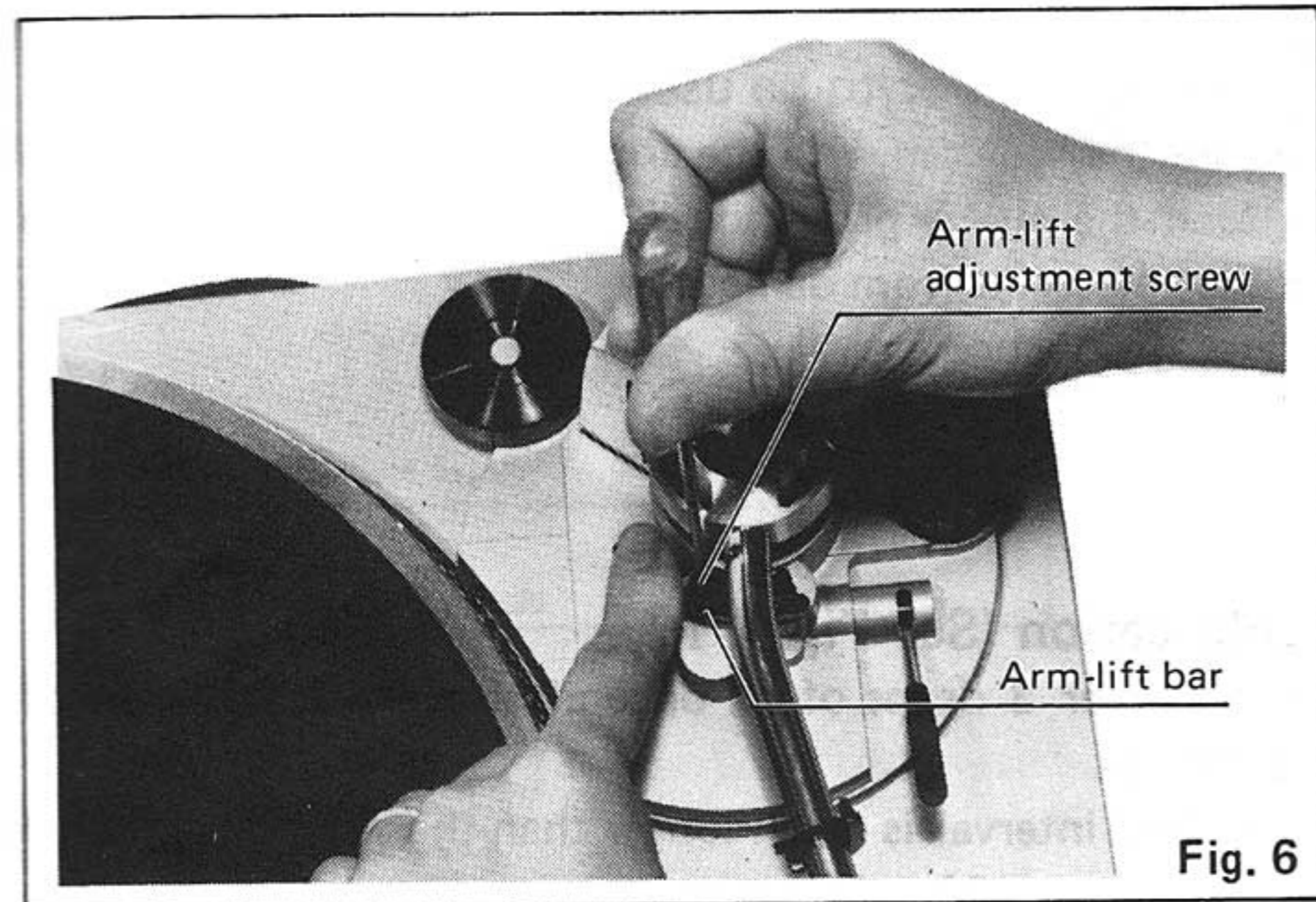
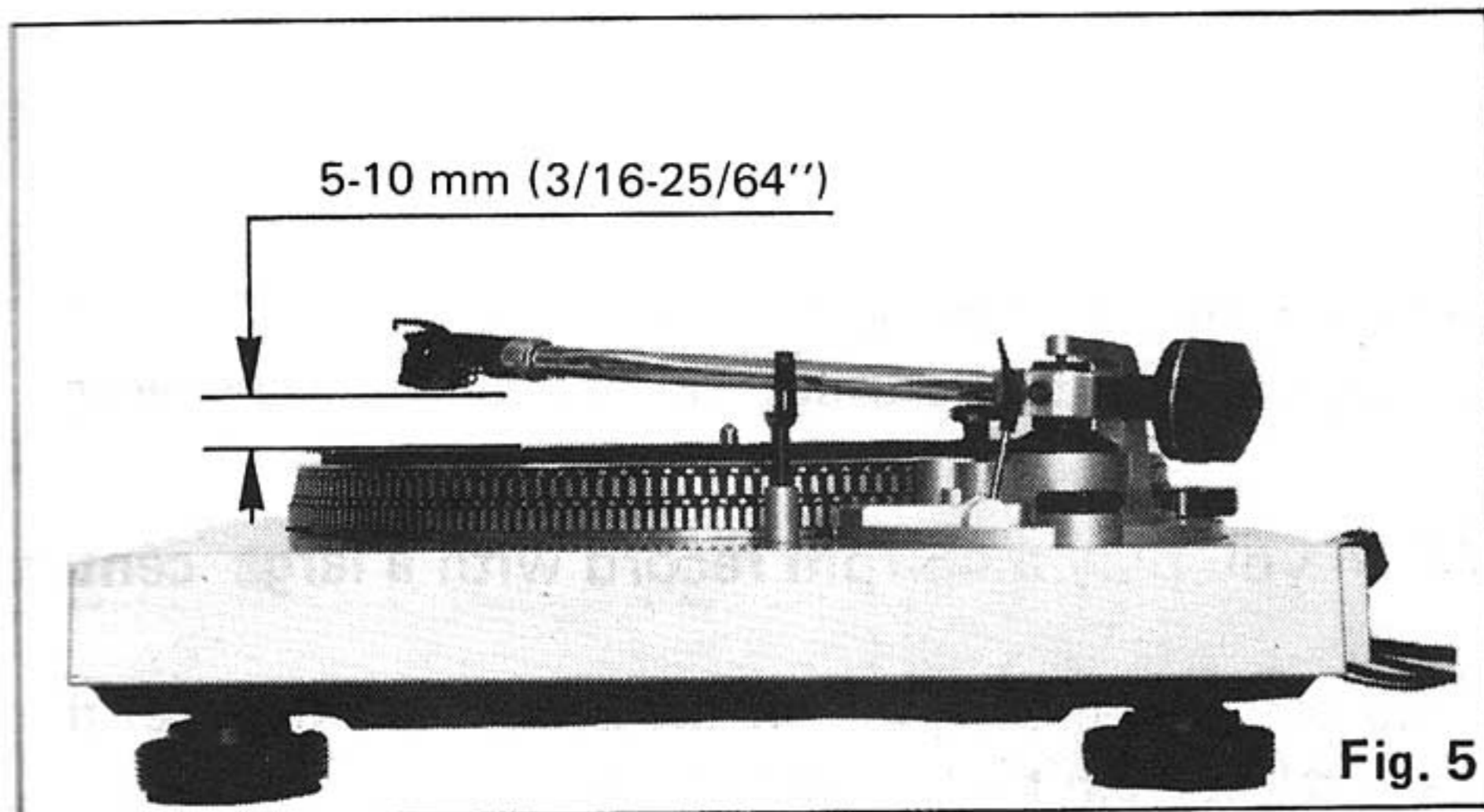

### Adjustment for automatic return position

(See Fig. 7.)

(Remove the turntable mat.)

In cases where the tonearm tends to return before the playing has finished.

—rotate clockwise

In cases where the tonearm fails to return after the last groove of the record has been played.

—rotate counterclockwise

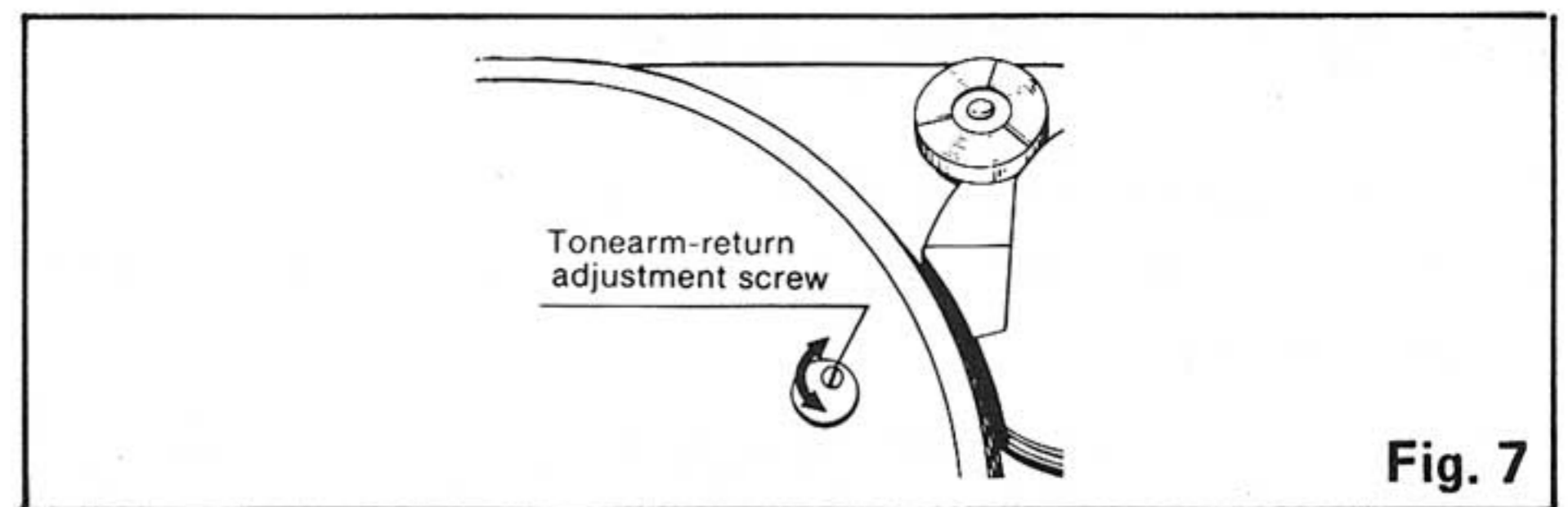

### Speed adjustment (with pitch-control knob)

(See Fig. 8.)

Strobe dots are set on the rim of the turntable platter according to the power-line frequency and the speed of the records. Make adjustment, referring to the strobe-dot indication.

1. Set the speed select knob to the speed to be adjusted.
2. Release the arm clamp and move the tonearm toward the record.

The strobe-illuminator/pilot lamp will light up and the turntable platter will rotate.

3. While turning the pitch-control knob either to the "+" side or "-" side, adjust so that the strobe dots of the turntable platter look as if they were stationary. This represents the correct speed.

#### "+" direction

The speed of the turntable platter will increase. Turn the knob in this direction if the strobe dots seem to be "falling back", i.e. seem to be moving counterclockwise. When the dots appear to be stationary, turntable speed is accurate.

#### "-" direction

The speed of the turntable platter will decrease. Turn the knob in this direction if the dots seem to be "running ahead", i.e. seem to be moving clockwise, until they appear stationary.

Moreover, the speed fine control knob can be used both for 33-1/3 rpm and 45 rpm.

Adjustment is to be made according to the selected speed (33-1/3 rpm or 45 rpm).

#### Note:

#### Strobe dot pattern

The strobe-illuminator/pilot lamp of this unit employs the standard commercial power source. The frequency of such power source, when actually measured, has a fluctuation of about 0.2%.

As such a fluctuation of the power source affects the strobe illuminator, the strobe dot pattern also seems to fluctuate to a certain extent. But the unit is not affected by these fluctuations of the power source, since a DC motor is employed.

In other words, rotation of the platter will be constant, and slight shifts in the movement of the dots simply reflect normal drift in the power-source frequency.

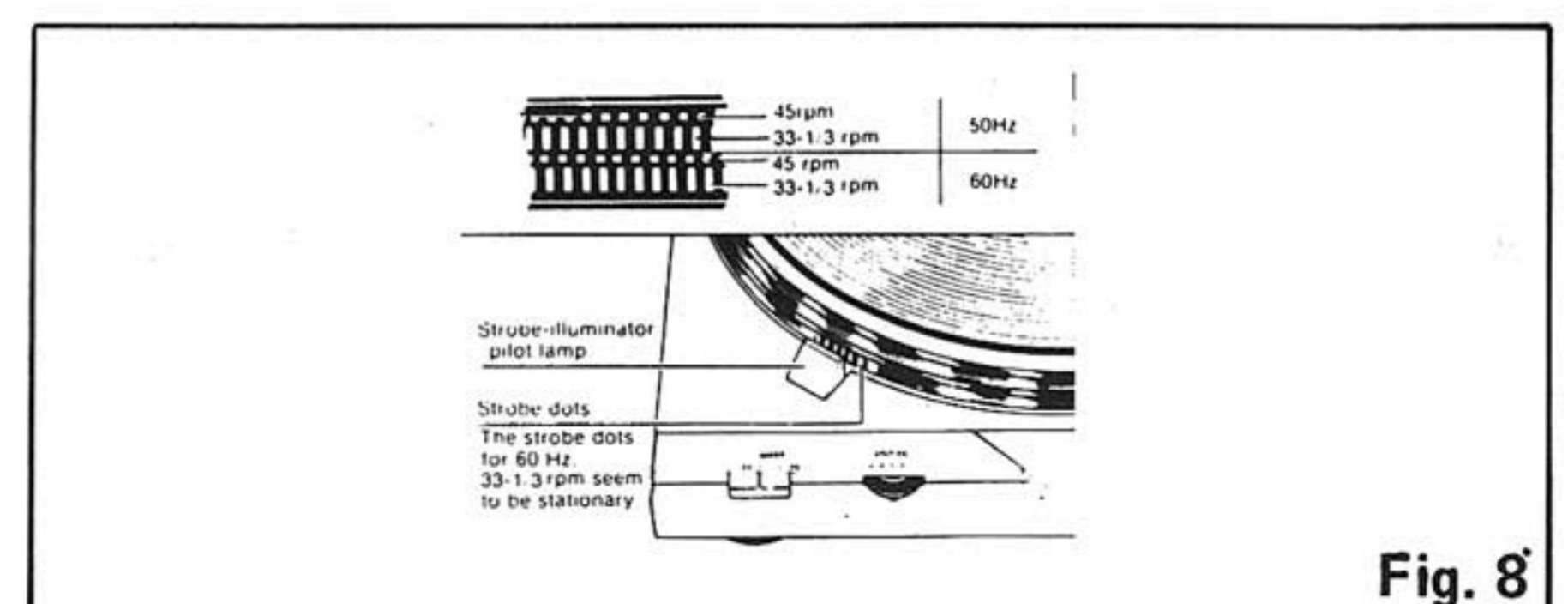

## ■ DISASSEMBLY PROCEDURE

### How to remove the bottom plate (Fig. 9)

- 1) Remove the head shell and turntable.
- 2) Secure the tone arm with the arm clumper.
- 3) Turn over the set taking care not to damage the dust cover.
- 4) Remove the 7 bottom plate setscrews **A**.

**Note)** Be careful not to lose the boss cap attached to the insulator on the cabinet side.

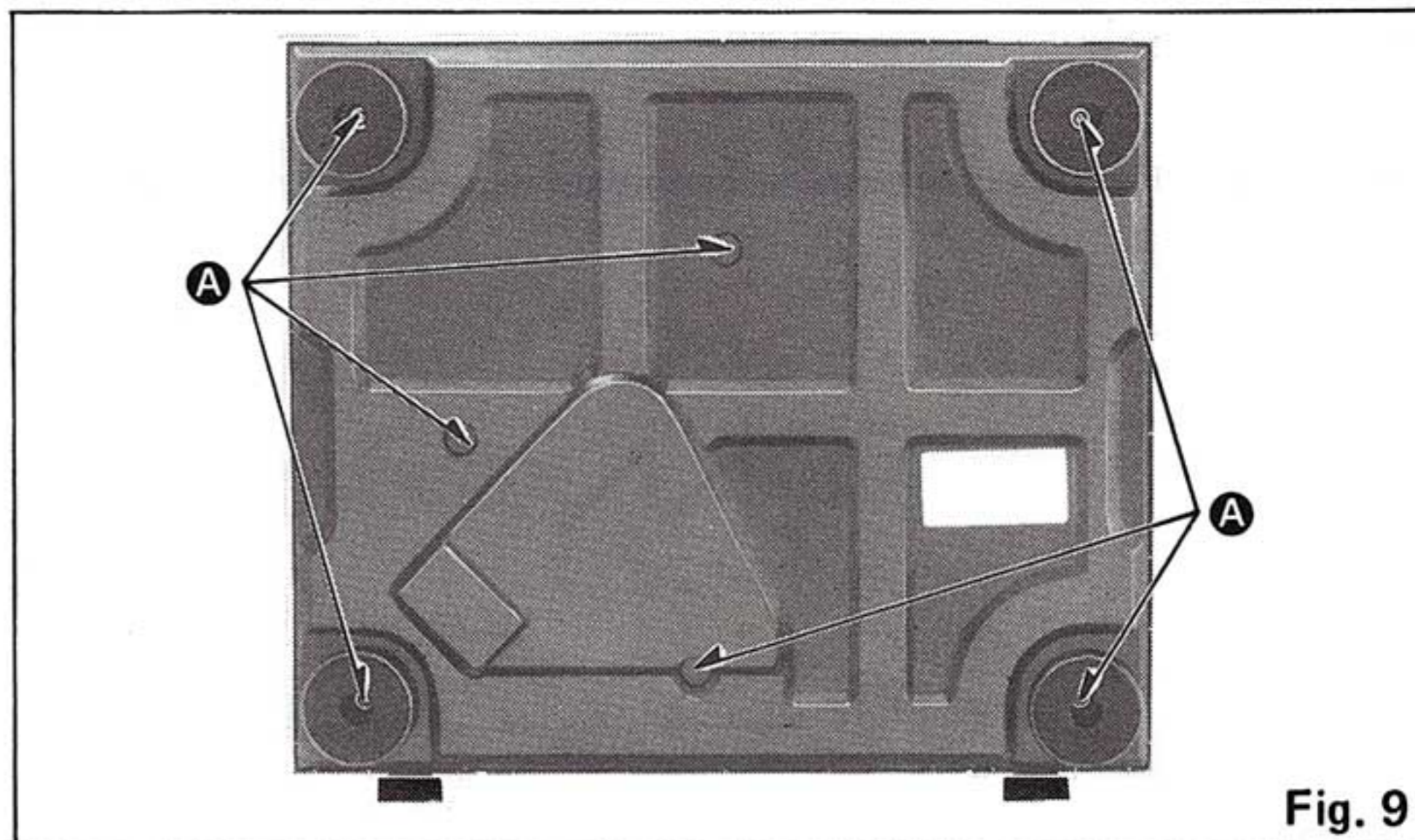

Fig. 9

### How to remove the radiating fin (Fig. 10)

- 1) Remove the bottom board as explained above.
- 2) Remove the 4 setscrews **B** of the radiating fin.
- 3) Remove the 2 setscrews **C** of the top radiating fin.

### Removal of drive P.C.B. and automatic mechanism ass'y (Fig. 10)

- 1) Remove the bottom board.
- 2) Remove the speed change knob.
- 3) Remove the 4 setscrews **D** of the automatic mechanism ass'y.
- 4) Remove the 4 setscrews **E** of the drive P.C.B..
- 5) Pull out the boards in the direction of the arrow **1** as illustrated.

**Note)** 1. Pull the start plate in the direction of the arrow **2** because it may otherwise come in touch with the tone arm fixing plate ass'y.

2. Since the neon cover is fixed being in contact with the drive P.C.B. take care not to lose the neon cover when removing the base palte.

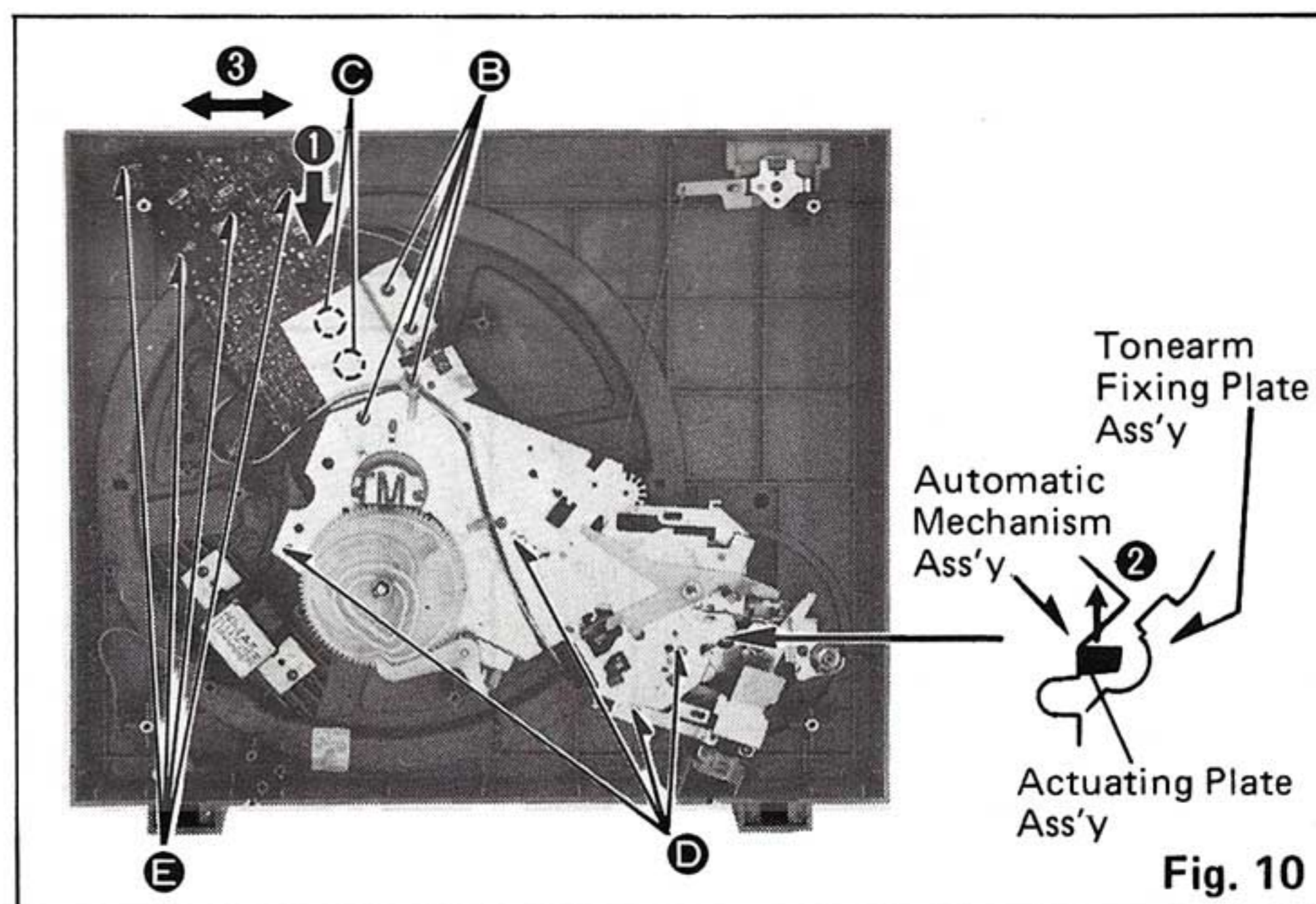

Fig. 10

### Removal of stater coil (Fig. 11)

- 1) Remove the 3 setscrews of the stator cover of the removed drive P.C.B..
- 2) Disconnect the 18 soldered parts of the stater coil.
- 3) Remove the 3 setscrews **F** of the stator coil and P.C.B. board.

Then, the stater coil can be removed. When installing, position the stater coil as shown by the arrow **4**.

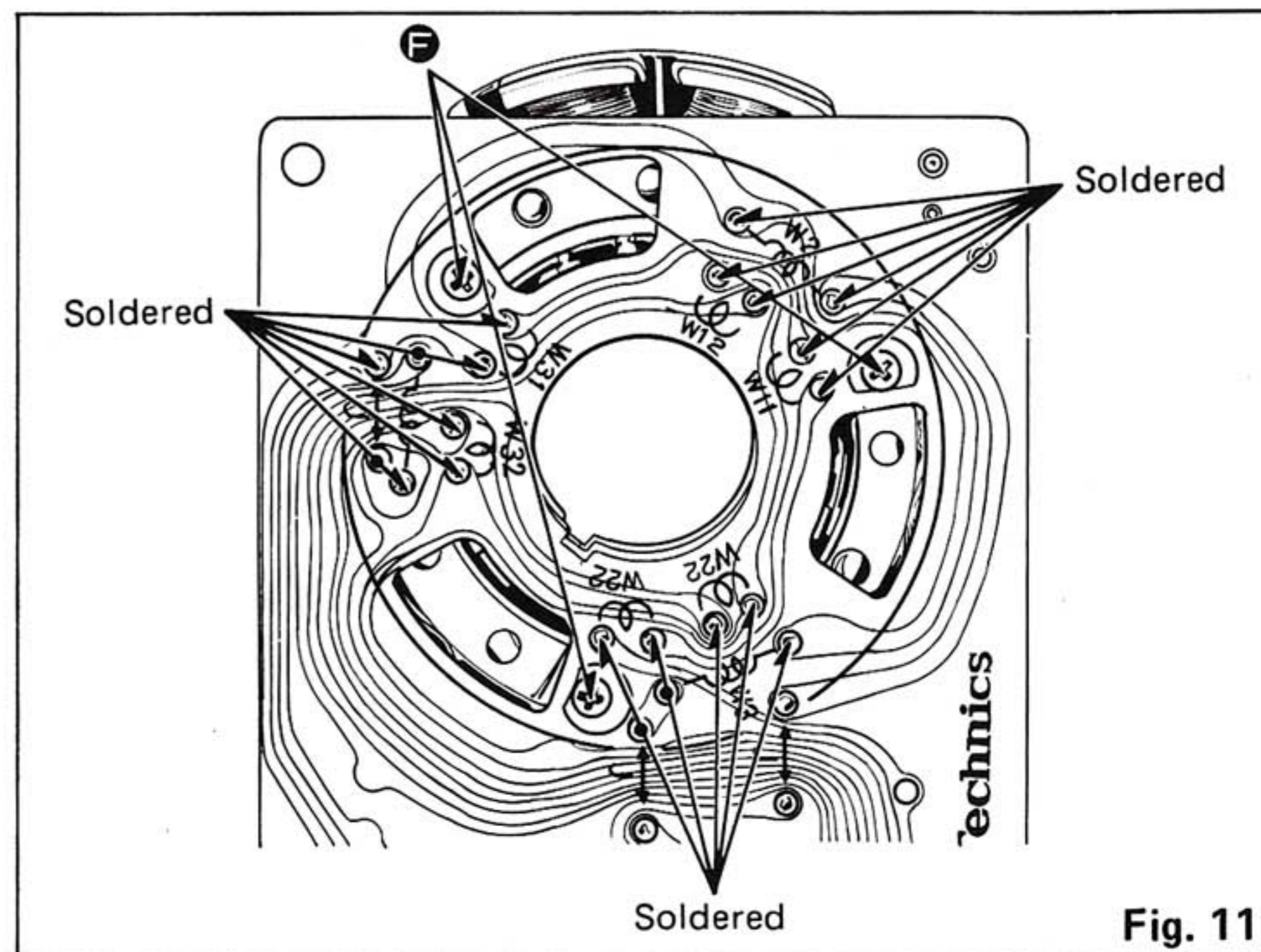

Fig. 11

### Precautions for assembly

**Note)** When assembling the mechanical and drive P.C.B., follow the procedure below. (Fig. 10)

- 1) Temporarily secure the 3 setscrews of the stator coil.
- 2) Secure the automatic mechanism ass'y with 4 setscrews. (Pull the actuating plate ass'y in the direction of the arrow 2 or otherwise it may touch the tone arm fixing plate ass'y.)
- 3) There is some clearance between the drive P.C.B. and automatic mechanism ass'y in the direction of the arrow 3. Find a position where the pitch control knob doesn't touch the cabinet, and then install the drive base plate with 4 setscrews.

# ■ PARTS ARRANGEMENT DIAGRAM

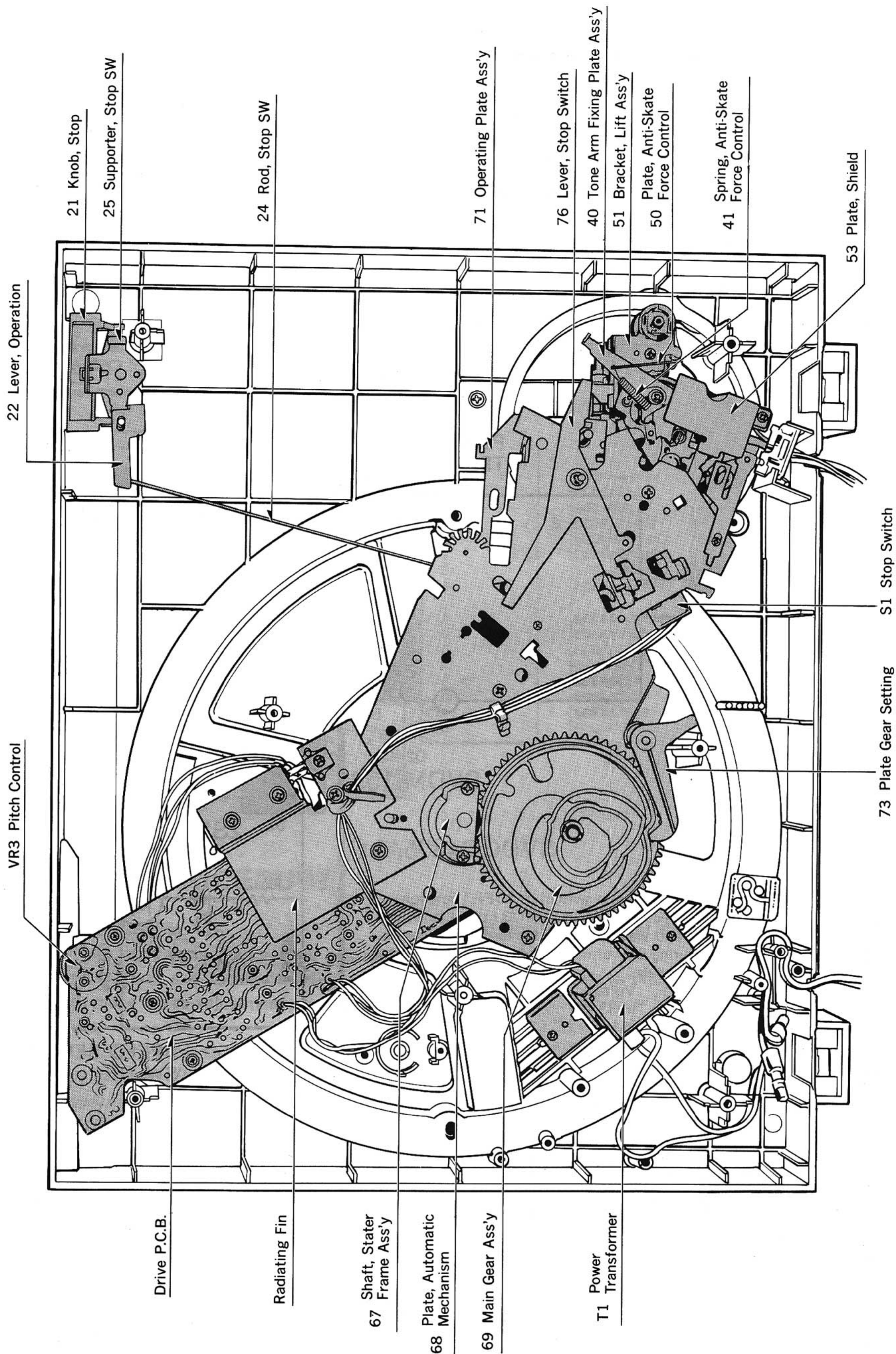

■ BLOCK DIAGRAM

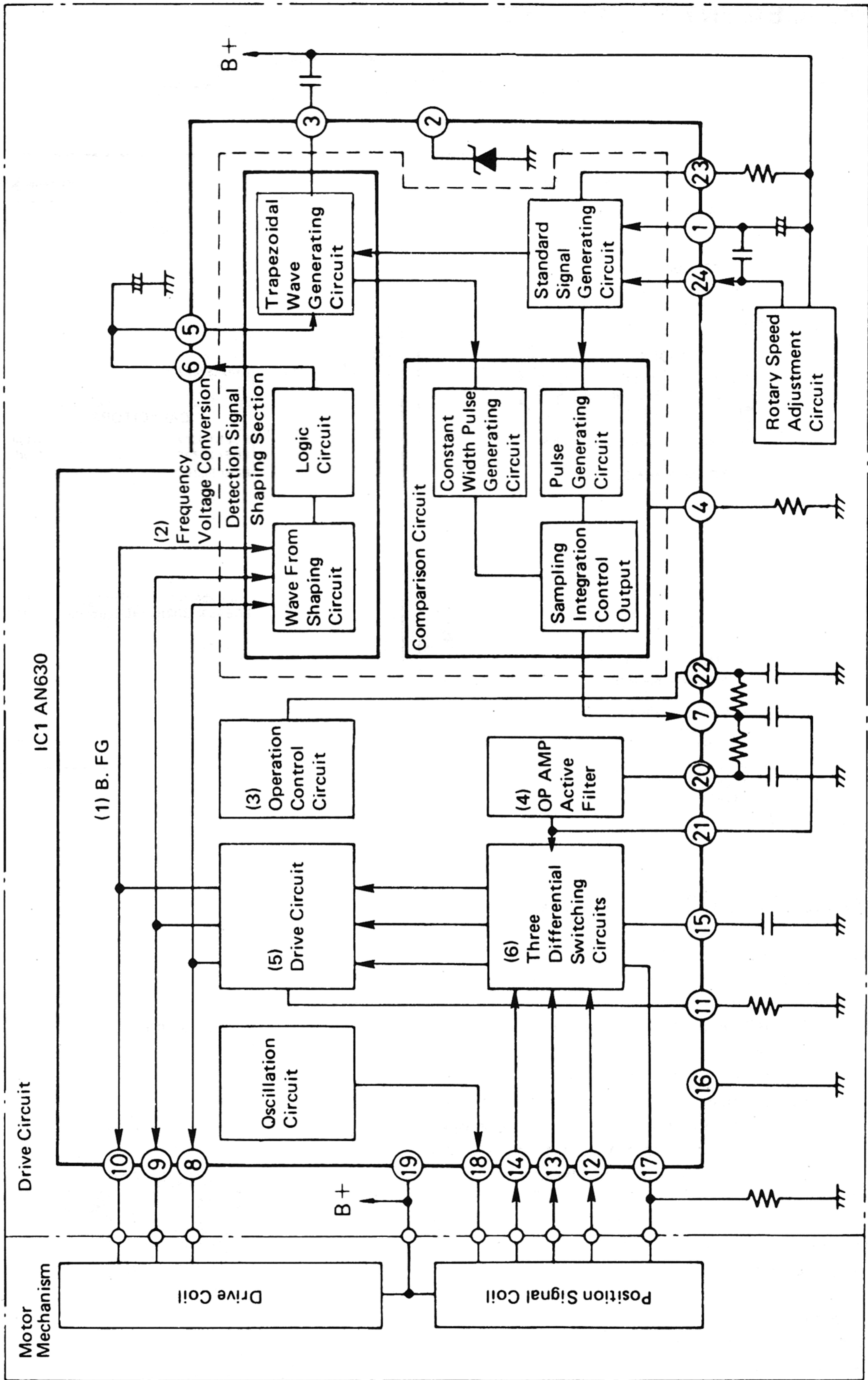

# REPLACEMENT PARTS LIST

- Notes: 1. Part numbers are indicated on most mechanical parts.  
Please use this part number for parts orders.  
2.  $\Delta$  indicates that only parts specified by the manufacturer be used for safety.  
3. SL-D2 (M)  $\rightarrow$  [M], SL-D2 (MC)  $\rightarrow$  [MC]

Ref. No.	Part No.	Part Name & Description
<b>INTEGRATED CIRCUIT</b>		
IC1	AN630U	Integrated Circuit
<b>TRANSISTORS</b>		
Q1	2SC1846-R	Transistor
Q2	2SD637	Transistor
Q3	2SB641	Transistor
<b>DIODES</b>		
D1	$\Delta$ SVDSIRBA40	Rectifier
D2	$\Delta$ SVDMI152	Rectifier
D3, 4, 5	20A90	Diode
D6	MA161	Diode
D7, 9	SVDGD4205ALC	Light Emitting Diode
<b>TRANSFORMER</b>		
T1	$\Delta$ SLT41PU1D	Power Transformer
<b>FUSE</b>		
F1 [MC] only	$\Delta$ XBA2F05NU100	500mA, Fuse
<b>SWITCHES</b>		
S1	$\Delta$ SFDSA74403	Switch, Power
S2	EVAH27SBCAAY	Switch, Speed Selector
<b>VARIABLE RESISTORS</b>		
VR1, 2	EVLS6AA00B54	50k $\Omega$ (B), Speed Control (33 r.p.m. & 45 r.p.m.)
VR3	EVJ61AT12B24	20k $\Omega$ (B), Pitch Control
<b>RESISTORS</b>		
R1	ERX1ANJ3R9	Metallic, 3.9 $\Omega$ , 1W, $\pm$ 5%
R2	ERD25FJ822	Carbon, 8.2k $\Omega$ , 1/4W, $\pm$ 5%
R3, 4	ERD25FJ472	Carbon, 4.7k $\Omega$ , 1/4W, $\pm$ 5%
R5	ERD25FJ330	Carbon, 33 $\Omega$ , 1/4W, $\pm$ 5%

Ref. No.	Part No.	Part Name & Description
R6	ERX1ANJ3R9	Metallic, 3.9k $\Omega$ , 1W, $\pm$ 5%
R7	ERO25CKF6202	Metal Film, 62k $\Omega$ , 1/4W, $\pm$ 1%
R8	ERD25TJ393	Carbon, 39k $\Omega$ , 1/4W, $\pm$ 5%
R9	ERD25TJ104	Carbon, 100k $\Omega$ , 1/4W, $\pm$ 5%
R10	ERD25TJ563	Carbon, 56k $\Omega$ , 1/4W, $\pm$ 5%
R11	ERD25FJ102	Carbon, 1k $\Omega$ , 1/4W, $\pm$ 5%
R12	ERO25CKF3902	Metal Film, 39k $\Omega$ , 1/4W, $\pm$ 2%
R13	ERD25FJ103	Carbon, 10k $\Omega$ , 1/4W, $\pm$ 5%
R14	ERD25FJ331	Carbon, 330 $\Omega$ , 1/4W, $\pm$ 5%
R15	ERD25TJ223	Carbon, 22k $\Omega$ , 1/4W, $\pm$ 5%
<b>CAPACITORS</b>		
C1	ECEB1HS471	Electrolytic, 470 $\mu$ F, 50V
C2	ECEA25Z4R7	Electrolytic, 4.7 $\mu$ F, 25V
C3	ECEA50ZR22	Electrolytic, 0.22 $\mu$ F, 50V
C4	ECQM1H104KS	Polyester, 0.1 $\mu$ F, 50V, $\pm$ 10%
C5	ECEA50ZR33	Electrolytic, 0.33 $\mu$ F, 50V
C6, 7	ECEA50N1	Non-polar Electrolytic, 1 $\mu$ F, 50V
C8	ECEA50N1	Non-polar Electrolytic, 1 $\mu$ F, 50V
C9	$\Delta$ ECQF2334KZ	Polypropylene, 0.33 $\mu$ F, 200V, $\pm$ 10%
C10	ECQM1H154KZ	Polyester, 0.15 $\mu$ F, 50V, $\pm$ 10%
C11	ECQM1H104KS	Polyester, 0.1 $\mu$ F, 50V, $\pm$ 10%
C12	ECEA25M10R	Electrolytic, 10 $\mu$ F, 25V
C13	ECEA50M2R2R	Electrolytic, 2.2 $\mu$ F, 50V
C14	ECEA50MR33R	Electrolytic, 0.33 $\mu$ F, 50V
C15	ECEA1VS330	Electrolytic, 33 $\mu$ F, 25V
C16	ECQM1H472KZ	Polyester, 0.0047 $\mu$ F, 50V, $\pm$ 10%
C17	ECQM1H473KZ	Polyester, 0.0047 $\mu$ F, 50V, $\pm$ 10%
C18, 19	ECEA50Z1	Electrolytic, 1 $\mu$ F, 50V
C20	ECEA50Z1	Electrolytic, 1 $\mu$ F, 50V
C21	ECEA1AS221	Electrolytic, 220 $\mu$ F, 6.3V
C23	ECQM1H333KZ	Polyester, 0.0033 $\mu$ F, 50V, $\pm$ 10%

## ADJUSTMENT PROCEDURE

### Adjustment of Speed (See Fig. 12)

If the number of revolutions cannot be correctly adjusted by replacing IC or other parts and turning the fine speed adjusting knob (VR3), make the re-adjustment according to the following procedure.

1. Set the fine speed adjusting knob to the central position.
2. In 33-1/3 r.p.m. mode, turn VR1 (33) so that the speed is adjusted to the specified point by using a stroboscope.
3. Next, in 45 r.p.m. mode, turn VR2 (45) so that the speed is adjusted to the specified point by using a stroboscope.
4. After the adjustment, shift the speed change switch and make sure that the speeds in 33-1/3 r.p.m. and 45 r.p.m. modes are as specified.

#### Note:

For the above adjustments, follow the disassembly procedure. Remove the bottom plate and put the set on a table for repair work and gain access to it from underneath.

It is also possible to adjust the set only with its turntable removed.

Remove the turntable as illustrated below, then a hole will be revealed from which a screwdriver can be inserted to turn VR1 and VR2.

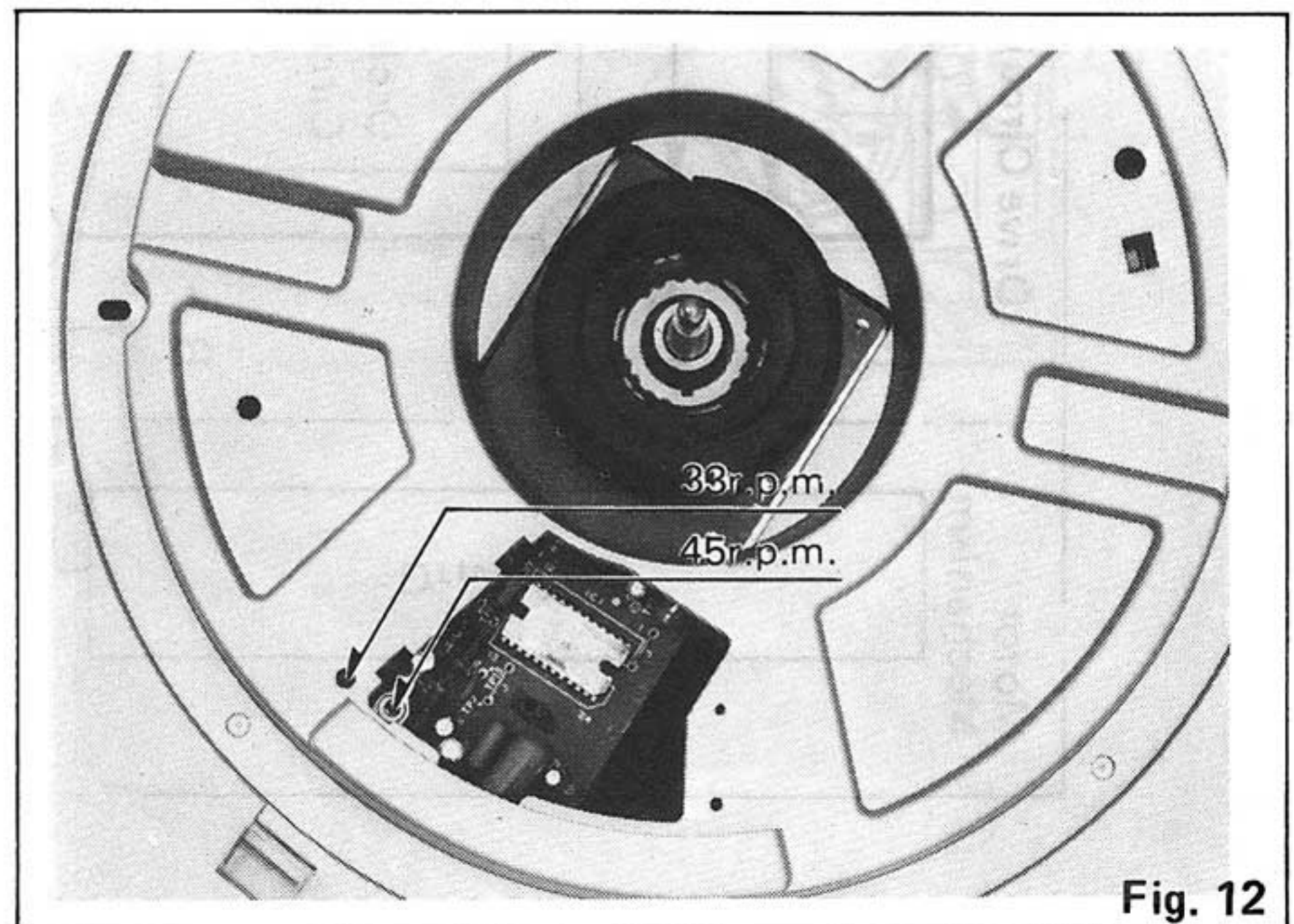
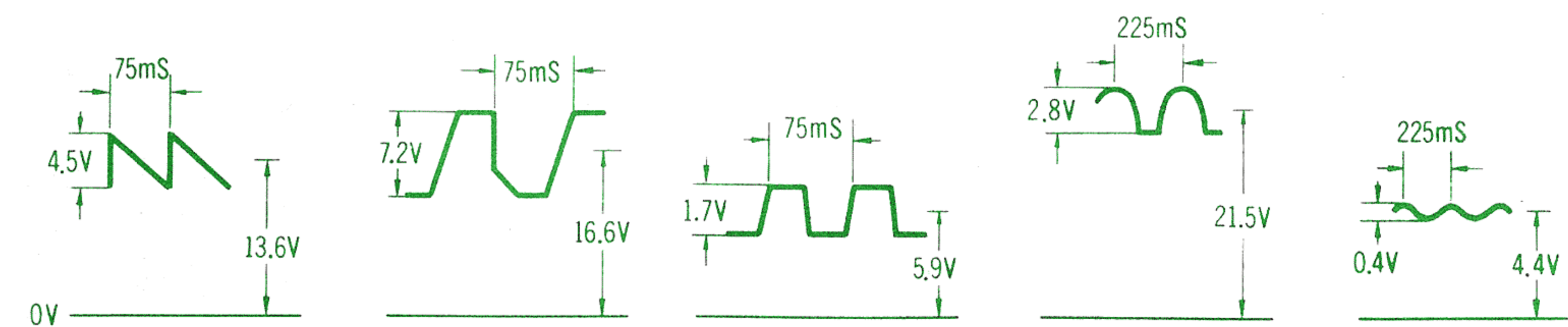


Fig. 12



# Schematic Diagram

(This schematic diagram may be modified at any time with the development of new technology.)



- Notes:
- S1: Power switch (Arm switch) in "OFF" position.
  - S2: Speed selector switch in "33-1/3 r.p.m." position.
  - The voltage and wave form are the results of measurement by using DC voltmeter and oscilloscope on the basis of the chassis.
- ..... Voltage measured by DC voltmeter in 33-1/3 r.p.m. mode. (S1 - N.O., S2 - 33)
  - Wave form .... Wave form measured by oscilloscope in 33-1/3 r.p.m. mode. (S1 - N.O., S2 - 33)
  - ( ) ..... Voltage measured by DC voltmeter in stop mode. (S1 - N.O., S2 - OFF)

## TERMINAL GUIDE OF TRANSISTOR AND IC

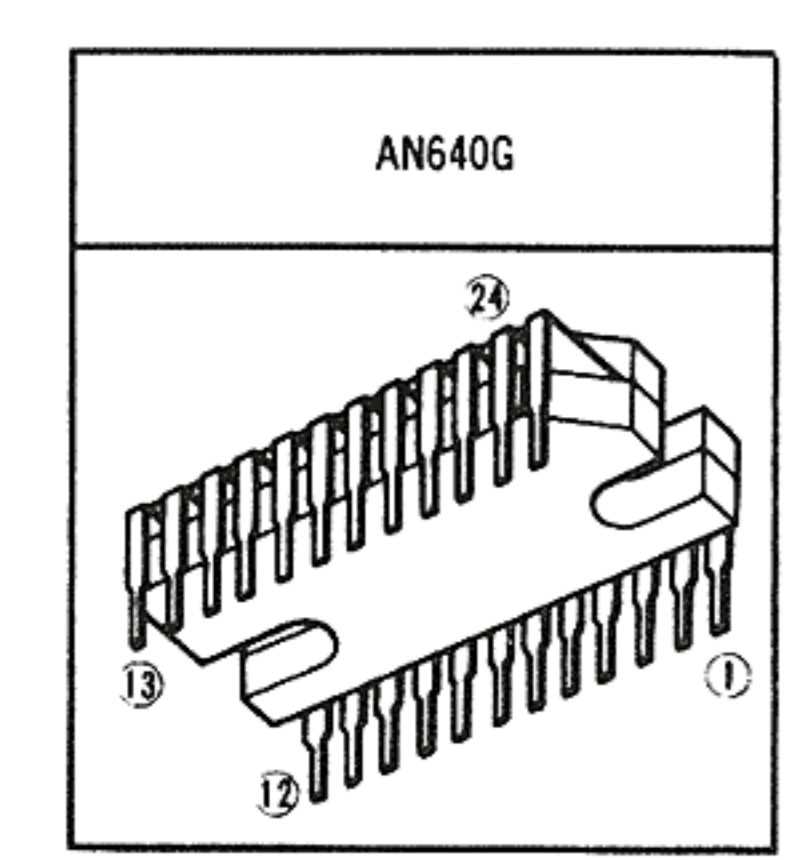

**IMPORTANT SAFETY NOTICE**

THE SHADED AREA ON THIS SCHEMATIC DIAGRAM INCORPORATES SPECIAL FEATURES IMPORTANT FOR SAFETY. WHEN SERVICING IT IS ESSENTIAL THAT ONLY MANUFACTURER SPECIFIED PARTS BE USED FOR THE CRITICAL COMPONENTS IN THE SHADED AREAS OF THE SCHEMATIC.

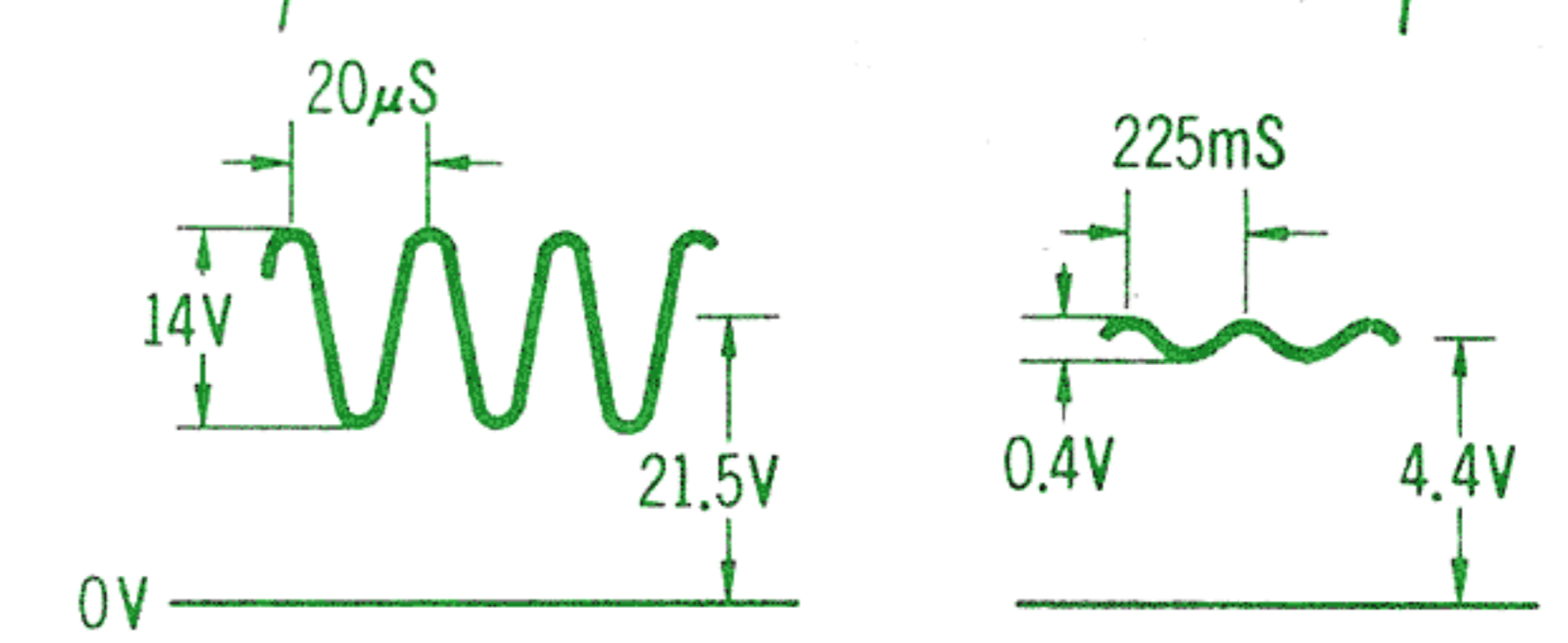

# Printed Circuit Board

Earth (Ground) lines  
 B lines



# EXPLODED VIEWS

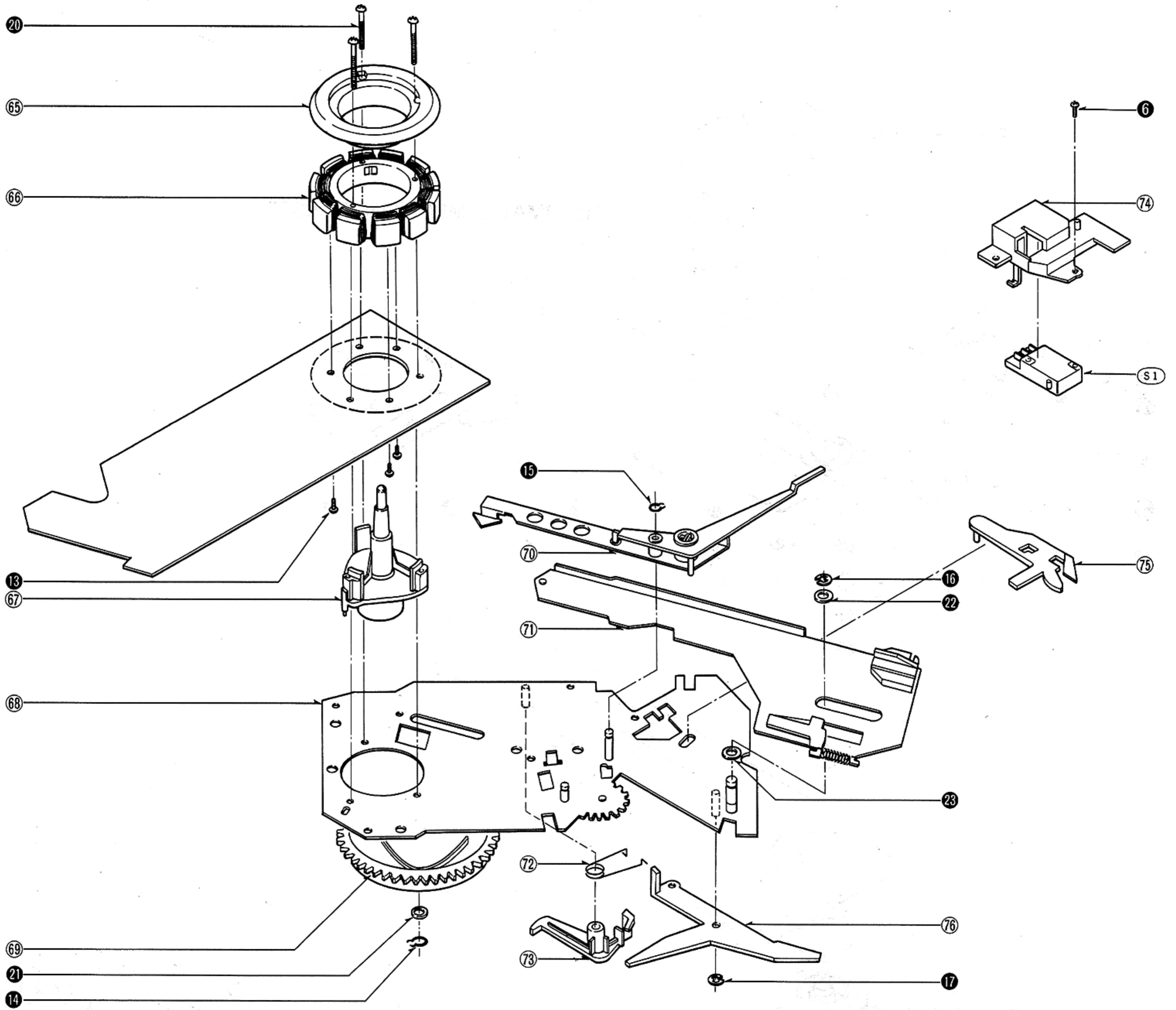

■ EXPLODED VIEWS



# REPLACEMENT PARTS LIST

- Notes: 1. Part numbers are indicated on most mechanical parts.  
Please use this part number for parts orders.  
2.  $\Delta$  indicates that only parts specified by the manufacturer be used for safety.  
3. SL-D2 (M)  $\rightarrow$  [M], SL-D2 (MC)  $\rightarrow$  [MC]

Ref. No.	Part No.	Part Name & Description
<b>CABINET and CHASSIS PARTS</b>		
1	SFADD20-01E	Dust Cover
2	SFTG320-01	Turntable Mat
3	SFTED20-01A	Turntable
4	SFUMD20-02	Spacer, LED
5	SFUPD20-04	Plat, Speed Select Switch
6	SFKTD20-03	Knob, Pitch Control
7	SFXWD20-01	Cap, Bottom Board
8	SFAUQ20-01	Bottom Board
9	SFQC200-02	Spring, Audio Insulator (Front)
10	SFGAQ20-01E	Audio Insulator
11	SFQC320-01	Spring, Audio Insulator (Rear)
12	SFKCD20-01	Panel, Cabinet
13	SFACD20-01	Cabinet
14	SFKTD20-02	Knob, Speed Select
15	SFUMQ20-05	Cover, Neon
16	SFGCD20-01	Cushion, Power Transformer
17	SFGCD20-01	Cushion, Power Transformer
18	SFUPD20-02	Supporter, Power Transformer
19	SFAT301-01A	Hinge Ass'y
20 (M)	SFNND20M01	Name Plate
20 (MC)	SFNND20C01	Name Plate
21	SFKTD20-01	Knob, Stop
22	SFUMD20-01	Lever, Operation
23	SFQAD20-01	Spring, Stop SW
24	SFUZD20-01E	Rod, Stop SW
25	SFUPD20-03	Supporter, Stop SW
26	$\Delta$ QFC1201MA	AC Cord
27	SJE41	Spacer, AC Cord
<b>TONE ARM and ARM BASE</b>		
35	SFPWG31101K	Balance Weight
36	SFPAM31101K	Tone Arm
37	SFPCC31001K	Headshell
38	SFPJK13101	Knob, Anti-skate Force Control
39	SFPAB13202	Knob, Cueing Lever
40	SFUPQ20-03A	Tone Arm Fixing Plate Ass'y
41	SFPSP00101	Spring, Anti-skate Force Control
42	SFDH212-01	Phon Cord
43	SFEL028-01E	Ground Wire
44	SFKU212-01E	Arm Rest
45	SFPRT13004K	Lift Ass'y
46	SFQA829-03	Spring, Lift Ass'y
48	SFGZD20-02	Supporter, Cueing
49	SFPJL00101K	Lever, Cueing
50	SFXJQ20-03E	Plate, Anti-skate Force Control
51	SFUPD20-01A	Bracket, Lift Ass'y
52	SFUM212-08	Clamper, Cord
53	SFUP683R04	Plate, Shield
<b>AUTOMATIC MECHANISM ASS'Y</b>		
65	SFMGQ20-01	Cover, Stater Frame Ass'y
66	SFMG170-01A	Stater Frame

Ref. No.	Part No.	Part Name & Description
67	SFMZQ20-01A	Shaft, Stater Frame Ass'y
68	SFUKD30-11E	Plate, Automatic Mechanism
69	SFUG190-22E	Main Gear Ass'y
70	SFUCQ20-11E	Actuating Plate Ass'y
71	SFUBQ30-11A	Operating Plate Ass'y
72	SFQS222-11	Spring, Gear Setting
73	SFUM222-11	Plate, Gear Setting
74	SFUMQ20-18	Cover, Stop Switch
75	SFUMQ20-16	Supporter, Stop Switch
76	SFUMQ20-17	Lever, Stop Switch
<b>SCREWS, WASHERS and CIRCLIPS</b>		
①	XSN2+4	Screw
②	XWA2B	Washer
③	XTN3+5B	Screw
④	XTV3+10B	Screw
⑤	XWG3	Washer
⑥	XTV3+8B	Screw
⑦	XTV3+14B	Screw
⑧	XTV3+20B	Screw
⑨	XTV3+10BFZ	Screw
⑩	XWA3B	Washer
⑪	XSN3+12S	Screw
⑫	XTN3+8B	Screw
⑬	XTN26+6B	Screw
⑭	XUB6FT	Circlip
⑮	XUB4FT	Circlip
⑯	XUC5FT	Circlip
⑰	XUC3FT	Circlip
⑱	SFXGD20-01	Screw
⑲	SFXG829-01	Screw
⑳	SFXGQ20-02	Screw
㉑	SFXW890B01	Washer
㉒	SFXW623-02	Washer
㉓	SFXW130-13	Washer
<b>ACCESSORIES</b>		
A1 [M]	SFNUD20M01	Instruction Book
A1 [MC]	SFNUD20C01	Instruction Book
A2	SFWE212-01	Adaptor, 45 r.p.m.
A3	SFPEN3302	Nut, Cartridge
A4	SFPEW9601	Washer, Head Shell
A5	SFCZV8801	Screw, Cartridge
A6	SFPEV9801	Screw, Cartridge
A7	SFYF05A06	Polyethylene Bag
A8	SFK0135-01	Overhang Gauge
A9	SFPZB3501	Shell Weight
<b>PACKING PARTS</b>		
P1 [M]	SFHPD20M01	Carton
P1 [MC]	SFHPD20C01	Carton
P2	SFHHD20-01	Pad, Front
P3	SFHHD20-02	Pad, Rear
P4	SFHD230-01	Pad, Top
P5	SFHDD20-02	Pad, Turntable
P6	SFYH60X60	Polyethylene Cover, Player Unite
P7	SFYH60X60	Polyethylene Cover, Dust Cover
P8	SFYH40X45	Polyethylene Cover, Turntable
P9	SFHSD20-01	Spacer, Tone Arm