

RECEIVED AUG 28 1975

<ART-126-0>

SERVICE MANUAL

STEREO TURNTABLE

PL-51A

KUT

<75C02M61K>

 **PIONEER**[®]

CONTENTS

1. SPECIFICATIONS	4
2. OPERATION	5
3. PRINCIPLE OF MOTOR OPERATION.....	6
4. ADJUSTMENT	7
5. EXPLODED VIEWS AND PARTS LIST	
5.1 Packing	8
5.2 Mechanism.....	11
6. SCHEMATIC DIAGRAMS, P.C. BOARD PATTERN AND PARTS LIST	
6.1 Schmatic Diagram	16
6.2 Power Supply Circuit Assembly (KWR-030).....	17



1. SPECIFICATIONS

PHONO MOTOR AND TURNTABLE

Motor	DC servo motor
Speed	Two speeds: 33-1/3 rpm, 45 rpm
Wow and flutter	0.05% (WRMS) or less
S/N	58dB or more (in case of using Pioneer cartridge model PC-50)
Turntable platter	31cm diam, Aluminum-diecast alloy

TO NEARM

Tonearm type	Static balance, S-shape, pipe arm
Effective arm length	221mm
Tracking error	+3° ~ -1°
Overhang	15.5mm
Usable cartridge weight	4g (min) ~ 14g (max)

SUBFUNCTIONS

- Large-size shock absorbers
- Anti-skating force control
- Lateral balance weight
- Oil-damping arm elevator
- Hinges (Free-adjustable)
- Speed fine adjusters (33-1/3rpm, 45rpm: for use in turntable speed adjustment with stroboscope and strobolight)

OTHERS

Power requirements	AC. 120V, 60Hz
Power consumption	5.2W (max)
Outer dimensions	480(W) x 410(D) x 185(H)mm 18-7/8(W) x 16-1/8(D) x 7-1/4(H) in.
Weight	11.5 kg, 26 lb

ACCESSORY GROUP

Overhang adjustment gauge	1
45 rpm adaptor	1
Weight plate (Cartridge weight-adjustable)	1
Head shell	1
Sub weight	1
Screwdriver	1
Output cord (Connection cord)	1
Cartridge mounting screws	10
Cartridge mounting nuts	2
Cartridge mounting washers	2
Operating instructions	1

NOTE: Specifications and the design subject to possible modification without notice due to improvements.

2. OPERATION

STROBOSCOPE and STROBOLIGHT

The proper part of the stroboscope band to read depend upon the power source and record speed as below.

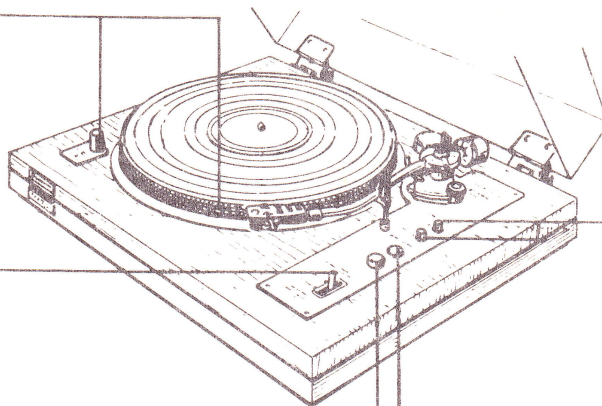
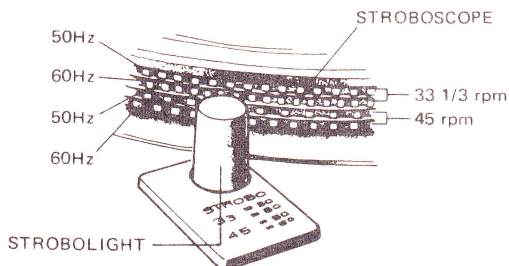

33-1/3 RPM BUTTON

Push this button for playing a 33-1/3 rpm speed record.

45 RPM BUTTON

Push this button for playing a 45 rpm speed record.

FUNCTION LEVER

This three-stage lever turns the motor on and off, and raises and lowers the tonearm.

- OFF Position
Shuts off power the motor, Stopping platter rotation.
- ON-UP Position
Switched from OFF this position causes the platter to begin moving and switch on the strobolight.
Switched from DOWN it raises the tonearm so that the stylus leaves the record surface smoothly.
- DOWN Position
When you are ready to begin record play move the lever to this position and stylus will lower gently onto the record.

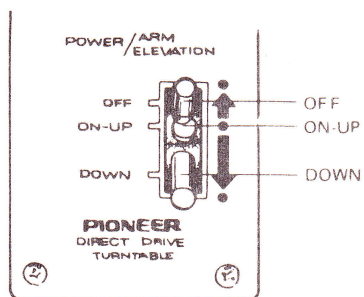

SPEED SELECT

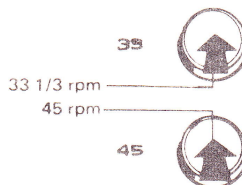

SPEED CONTROL KNOBS

With either of the speed selectors pressed, watch the appropriate stroboscope band and strobolight. Adjust for precise speed (so that the band appears to stand still) by turning that speed control knobs. Turn toward + (clockwise) for faster speed, toward - (counterclockwise) for slower. When the stroboscope appears to stand still, the speed is correct.

SPEED CONTROL

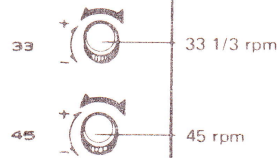

3. PRINCIPLE OF MOTOR OPERATION

Construction of motor control for the PL-51A is depicted in Fig. 2.

1. Applying power sets the oscillator into operation. Output of this circuit passes to the pole position detecting circuit (L1~L6).
2. Here, assume that coupling between L1 and L4 is the tightest. Voltage induced in L4 is rectified and applied to Q106/Q109 in the driver.
3. Q109 in turn conducts and causes current to flow in the associated drive coil (A-1). The rotor moves in the direction shown by arrow in Fig. 1. The magnetic pole affixed to the rotor induces a voltage proportional to rotor movement, in the sensing coil (A-4).
4. Voltage induced in A-4 is rectified by a diode in the speed sensor and applied to Q103 in the control stage. This point is also fed from the reference voltage generator (voltage E_s) through a fine speed control pot.
5. Voltage applied to the base of Q103 in the control stage controls current that flows in Q104.
6. Q104 serves as a constant current source for Q106 through Q111 in the driver and therefore controls current flow in the drive coils.
7. When ambient temperature change causes driver current to rise, the speed of rotation increases above the rated value. Q104 current increases and Q106~Q111 currents decrease. As a result, the speed of rotation falls off.

Pole Position Detector

Fig. 1 shows a simplified view of the drive and sense coils. With power applied and coupling between L1 and L4 high, Q109 causes current to flow through A-1. As a result, the rotor end of coil A-1 becomes a south pole (S1) and attracts N1. The rotor moves in the direction shown by arrow. Coupling factor between L2 and L5 increases and operation of Q110 causes current to flow in coil A-2. Pole S2 attracts pole N2 and rotor rotation continues. In the same manner, S3 attracts Pole N3. Continuation of this process causes the rotor to turn on a steady basis.

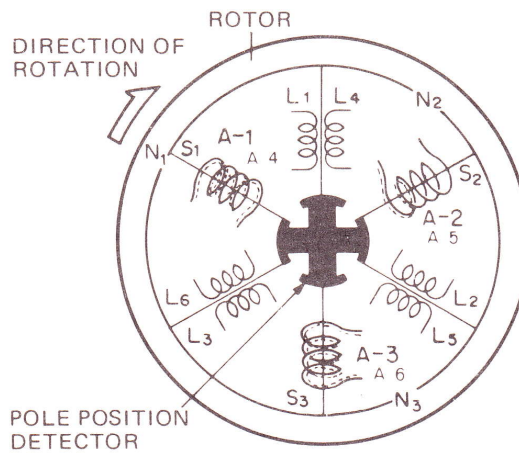

Fig. 1

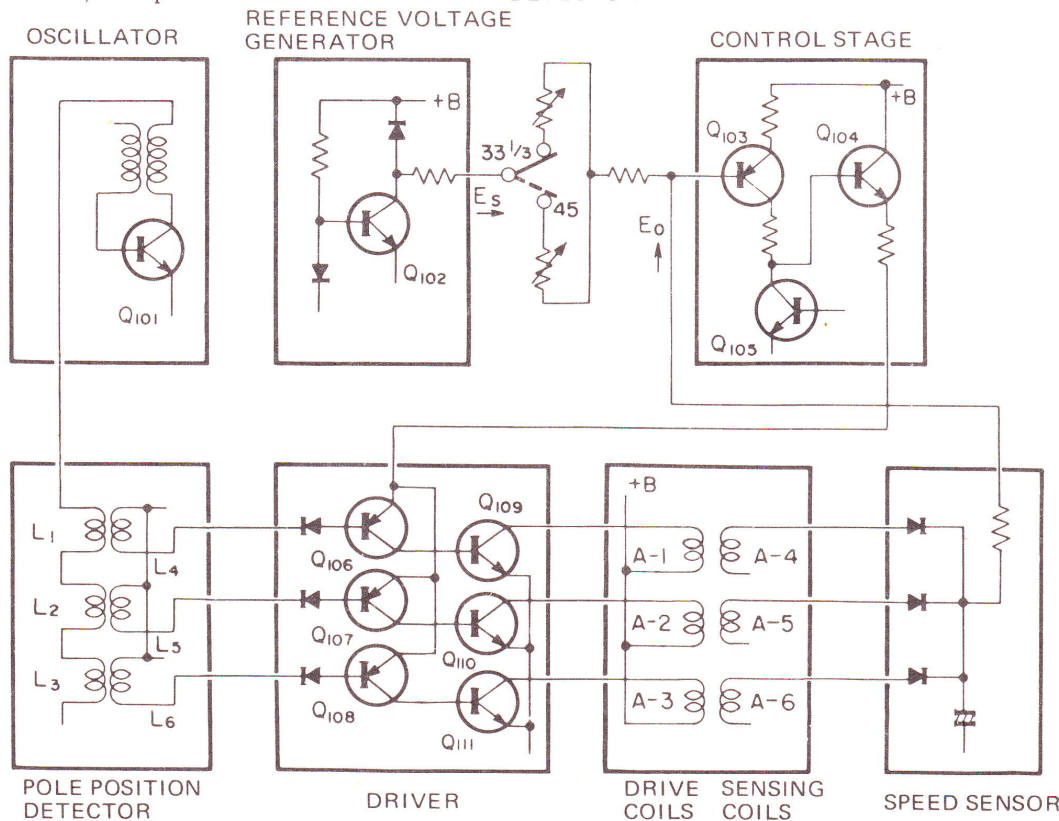

Fig. 2

4. ADJUSTMENT

When adjustment of the fine speed control does not give a satisfactory speed, adjust the motor in accordance with the following procedure.

1. Remove the bottom cover.
2. Set the fine speed control to the midposition.
3. While observing the edge of the turntable platter with a strobe, adjust screws inside the motor as shown in Fig. 3.
4. Alternate switching between 33-1/3 and 45 rpm speeds while making adjustment. Make sure that both speeds are correct.

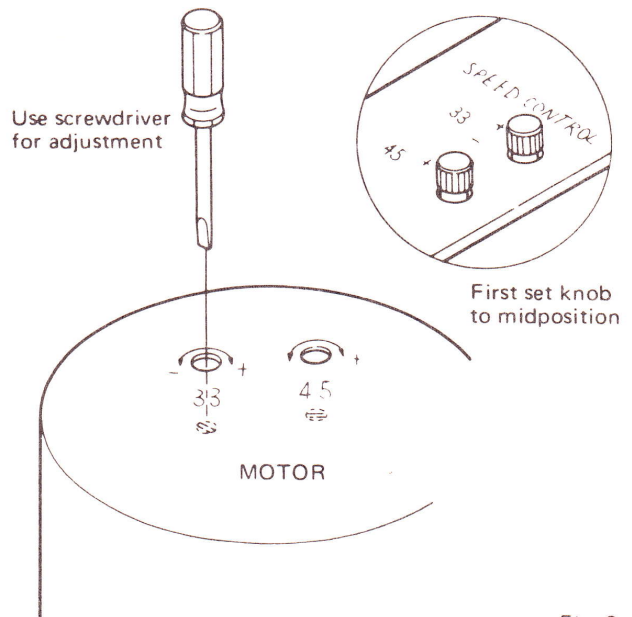

Fig. 3

Selection of Line Voltage

If model PL-51 does not agree with the line voltage of your service area, set the unit to the proper line voltage as follows:

1. Remove the bottom cover, now you can see the terminal board (Fig. 4).
2. Unsolder the lead (White) from the terminal.
3. Solder the lead (White) to the terminal of your local line voltage.

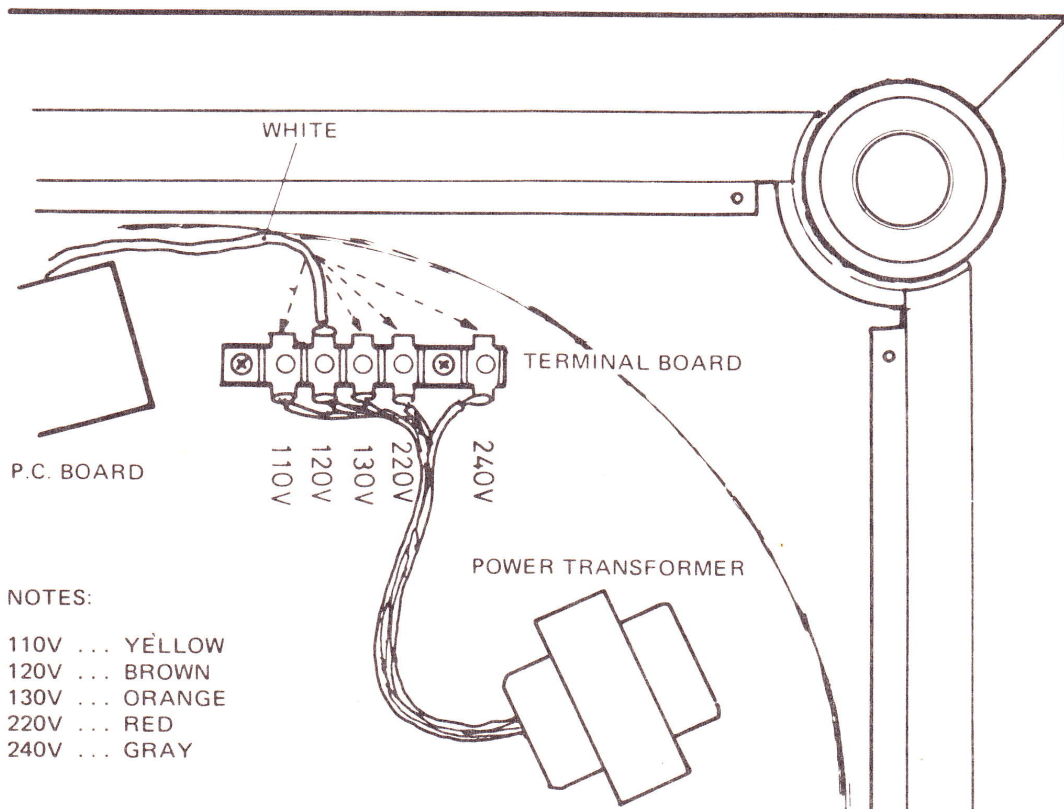

Fig. 4

5. EXPLODED VIEWS AND PARTS LIST

5.1 PACKING

NOTICE: Any parts asterisked(*) are subject to being not supplied.

Key No.	Description	Part No.	
1	Rubber mat	KEB-058-0	
2	Rubber mat ring	KAH-007-A	
3	Card board	H52-632-0	
4*	Rubber mat bag 345 x 395 x 0.05(t)mm		
5*	Vinyl bag	E11-024-0	
6	Operating instructions	KRB-064-A	
7	Top packing	KHC-059-0	
8	Dust cover	KNK-266-A	
9*	Dust cover bag 700 x 650 x 0.05(t)mm		
10	Styrotector (A)	KHA-226-B	
10-1	Styrotector (B)	KHA-227-A	
11*	Unit (PL-51)		
12	Vinyl cover	H56-603-0	
13			
14	Furnished parts box	KHX-026-B	
15	Screwdriver	KEX-002-A	
16	EP adaptor	KNK-055-B	
17	Main weight assembly	KXA-566-A	
18	Lateral balance weight	KXA-420-B	Attached 19
19	Set screw M4 x 5		
20	Subweight A	KLA-131-0	
21	Overhang checker	KNK-290-0	
22	Parts Box cover	KHX-027-0	
23	Connection cables	PDE-004-A	
24	Weight plate	N64-698-A	
25	Screw (13mm)	B11-044-C	
	(11.5mm)	B11-657-0	
	(8mm)	KBA-043-0	
	(5mm)	KBA-044-0	
	(15mm)	KBA-045-0	
26	Washer	B23-642-0	
27*	Vinyl bag 50 x 70 x 0.03(t)mm		
28	Nut	B71-653-A	
29*	Head Shell		
30	Turntable platter	KNH-108-0	
31*	Vinyl bag 345 x 395 x 0.05(t)mm		
32	Packing case	PHG-034-0	
33	Packing stopper	KHK-403-0	
①*	Rubber mat assembly	KEA-019-0	

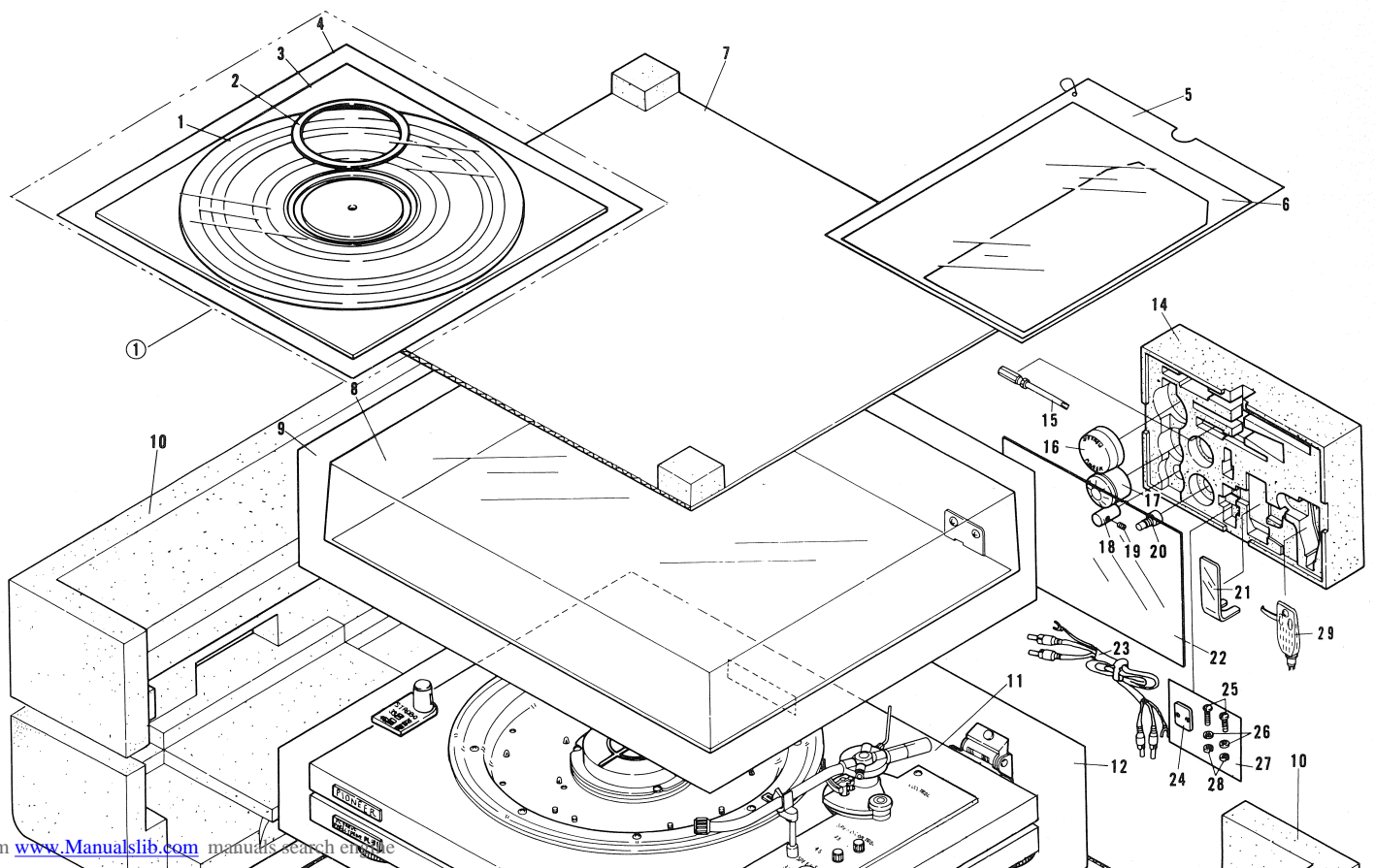

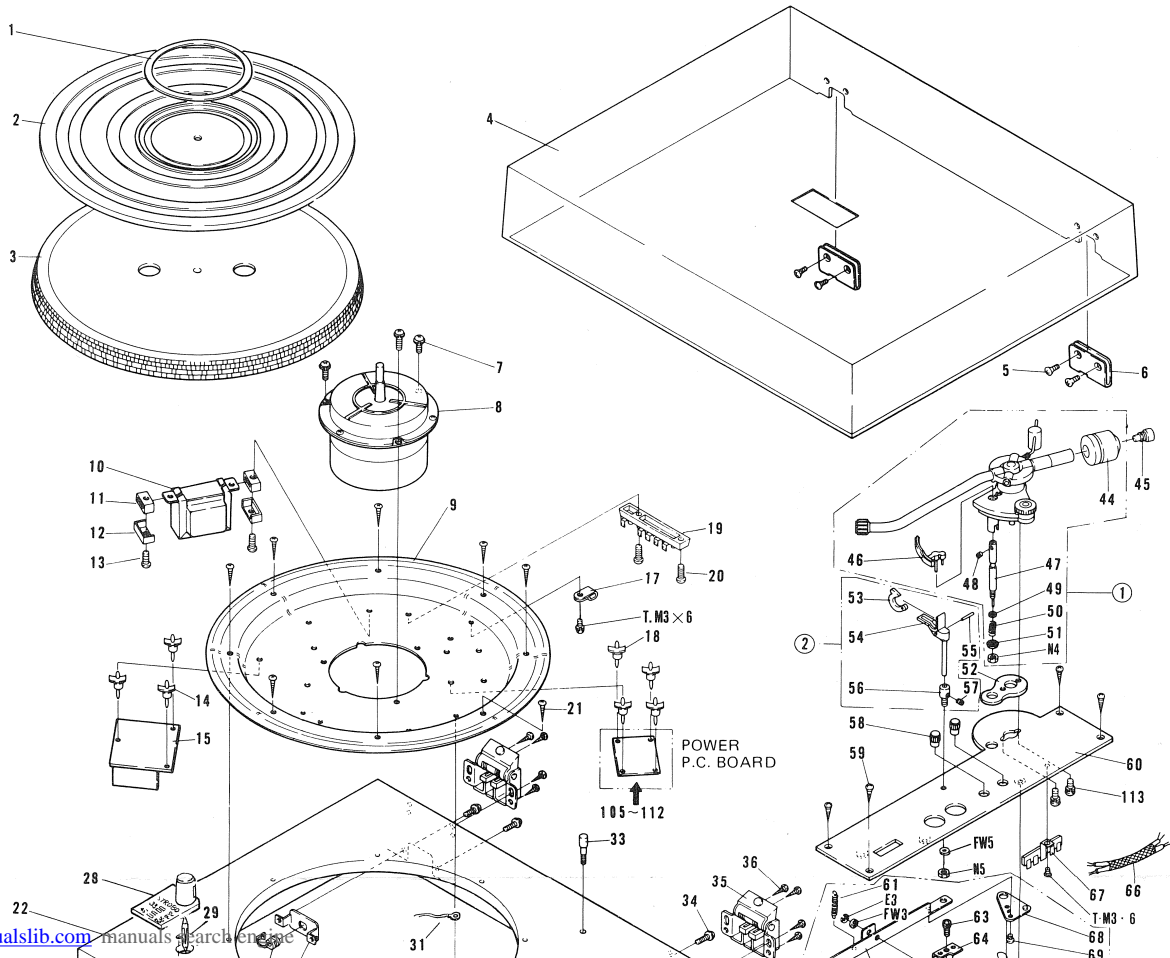

The following symbols stand for screws, nuts, washers, etc.
as shown in EXPLODED VIEW on pp. 9-10.

- N nut
- FW flat washer
- SW spring washer
- E E-type washer
- T Tapping screw

Parts List of Mechanism

NOTES:

- Sems A: Screw and spring washer
- Sems B: Screw, spring washer and flat washer
- Sems F: Screw and flat washer

NOTICE: Any parts asterisked (*) are subject to being not supplied.

Key No.	Description	Part No.	
1	Rubber mat ring	KAH-007-A	
2	Rubber mat	KEB-058-A	
3	Turntable platter	KNH-108-0	
4	Dust cover	KNK-266-A	
5	Oval countersunk head screw M4 x 10		
6	Lock plate	N61-084-0	
7	Pan head sems A screw M4 x 8		
8	Motor	KXM-021-G	
9*	Motor base	KNA-572-F	
10	Power transformer	KTU-015-0	(or KTT-016-0)
11	Transformer base rubber A	KEB-063-0	
12*	Transformer holder	KNA-603-A	
13	Pan head sems F screw M4 x 15		
14*	Boss	KNK-186-A	
15	Power supply circuit Ass'y	KWR-030-E	
17	Cord fixer	KEX-004-0	
18*	Boss	KNK-186-A	
19	Terminal board (5P)	KKE-006-B	
20	Pan head screw M4 x 12		
21	Wood screw 3.1φ x 13		
22	Upper board	KMM-093-A	
23	Insulator (G)	KXA-796-B	
24	Insulator (H)	KXA-797-B	
26	Power cord grommet	E32-056-0	
27*	Plate	KNA-522-C	
28	Lamp cover	KAK-046-0	
29	Strobo lamp	KEL-004-C	
30	Pan head sems F screw M3 x 12		
31	cord	KDX-006-A	
32			
33	Adaptor catch	KLA-601-0	
34	Pan head sems F screw M3 x 15		
35	Spring hinge assembly	KXA-603-B	
36	Wood screw 3.1φ x 13		
37			

Key No.	Description	Part No.	
38	Under board	KNA-629-E	Attached 23, 24, 104
39	Plate	KAM-090-0	
40	Tapping screw M3 x 10		
41	Washer 4φ		
42	Pan head sems A screw M3 x 5		
43			
44	Main weight assembly	KXA-566-A	
45	Sub weight A	KLA-131-0	
46	Elevator arm	KXA-392-0	
47	Elevation shaft	KLA-350-A	
48	Set screw M2.6 x 2		
49	Washer	KBE-008-0	
50	Spring	KBH-022-A	
51	Washer	KNA-125-A	
52	Arm base	PNW-001-0	
53*	Arm clamp	PNW-028-A	
54*	Arm rest	PNW-027-A	
55*	Clamp pin	KLA-111-0	
56*	Rest stand	KLA-240-0	
57	Set screw M2.6 x 3		
58	Knob	KLA-518-A	
59	Wood screw 3.1φ x 16		
60	Arm board	KNA-761-0	
61	Spring	KBH-066-A	
62*	Arm lift plate	KNA-328-0	
63	Pan head sems A screw M3 x 5		
64*	Lifter shaft angle	KXA-583-A	
66*	Cable	PDA-001-0	
67	Terminal strip (1L4P)	KKC-021-0	
68*	Lift plate	KNA-576-0	
69	Pan head sems A screw M3 x 5		
70*	Leaf spring	KBK-016-A	
71	Pan head sems A screw M3 x 5		
72	Push button	KLA-527-D	
73*	Button shaft	KLA-530-C	
74	Spring	KBH-099-0	
75*	Lifter base	KXA-581-D	
76	Pan head sems A screw M4 x 6		
77*	Bail lever	KNA-192-B	
78	Spring	KBH-029-E	

Key No.	Description	Part No.	
79	Pan head sems B screw M3 x 5		
80	Pan head sems A screw M3 x 5		
81*	Leaf spring	KBK-016-A	
82*	Steel ball (5/32")		
83*	Bail lever shaft	KLA-154-0	
84	Rubber washer (t=1)		
85	Teflon washer		
86*	Lever	KNA-191-B	
87*	Spacer (A)	KLA-155-B	
88	Microswitch	KSF-023-0	
89	Pan head sems A screw M3 x 16		
92	Pan head sems A screw M3 x 16		
93	Potentiometer (Fine speed adjustment)	KCS-006-A	
94	Function lever	KLA-574-0	
96*	Cam	KXA-582-A	
97	Power cord	KDG-011-0	
98	Terminal board assembly	KXA-571-F	
99	Plate	KNK-253-D	
100	Plate	KNK-254-C	
101	Wood screw 3.1 ϕ x 16		
102			
103	Pan head sems F screw M3 x 8		
104	Bottom cover	KMS-074-0	
105	Power supply P.C. board	KNP-065-A	
106	Capacitor 0.033 μ F	KCE-009-0	
107	Capacitor 0.01 μ F 1.4kV	C43-003-0	
108*	Mylar tape		
109*	Terminal (B)	KNK-222-0	
110	Fuse holder	K91-006-0	
111	Fuse 0.3A (Wired in type)	E21-030-0	
112*	Terminal (L-shaped)	K28-003-0	
113	Pan head sems A screw M3 x 10		
114	Metal oxide 10k 2w	RS2P 103J	
①	Tonearm assembly	PPD-520-A	Excluding head
②	Arm rest assembly	PXA-030-A	
③	Operation mechanism assembly	KXA-664-G	

6. SCHEMATIC DIAGRAMS, P.C. BOARD PATTERN AND PARTS LIST

6.1 SCHEMATIC DIAGRAM

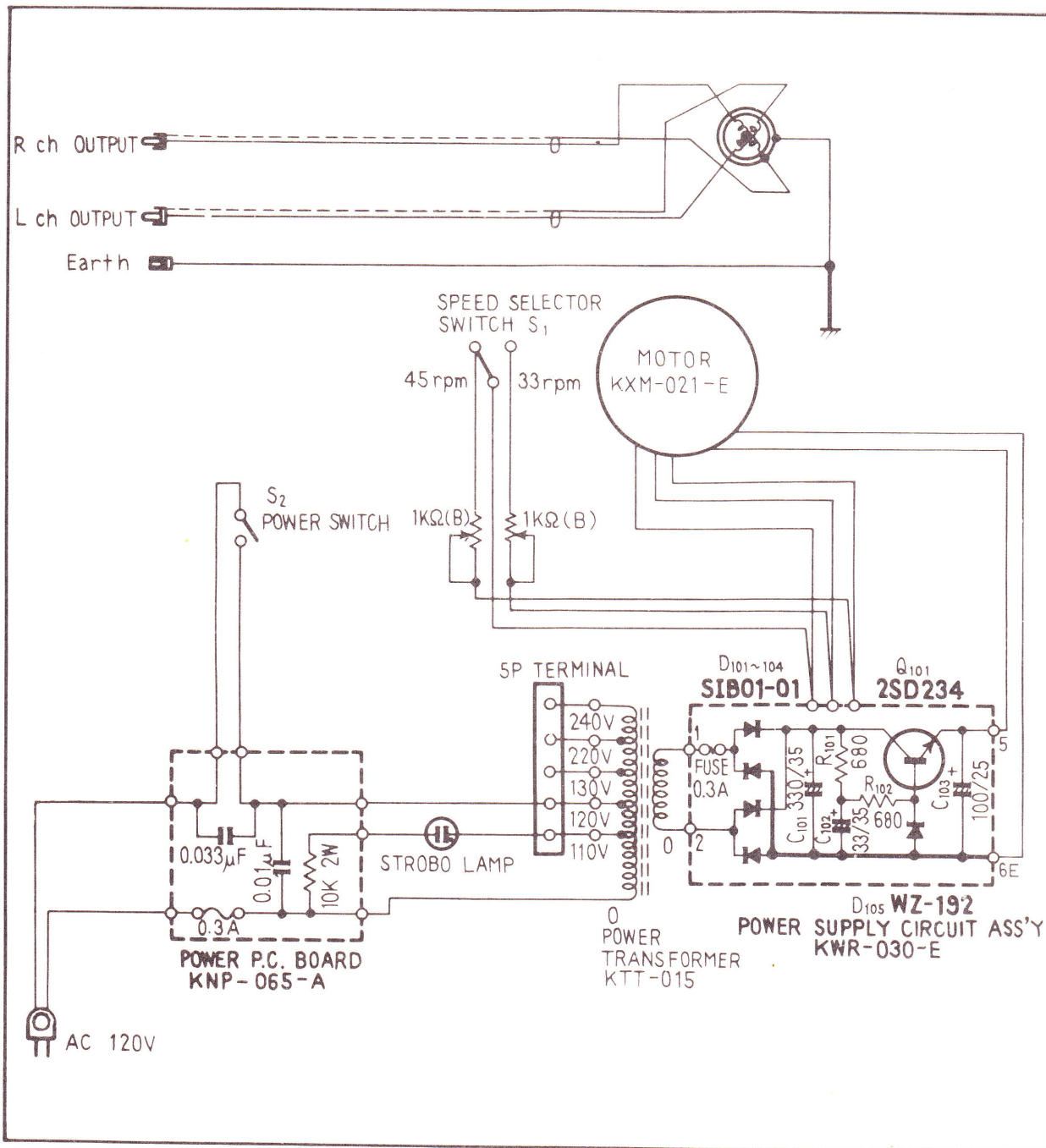

2SD234

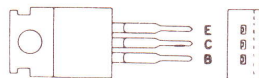

6.2 POWER SUPPLY CIRCUIT ASS'Y (KWR-030)

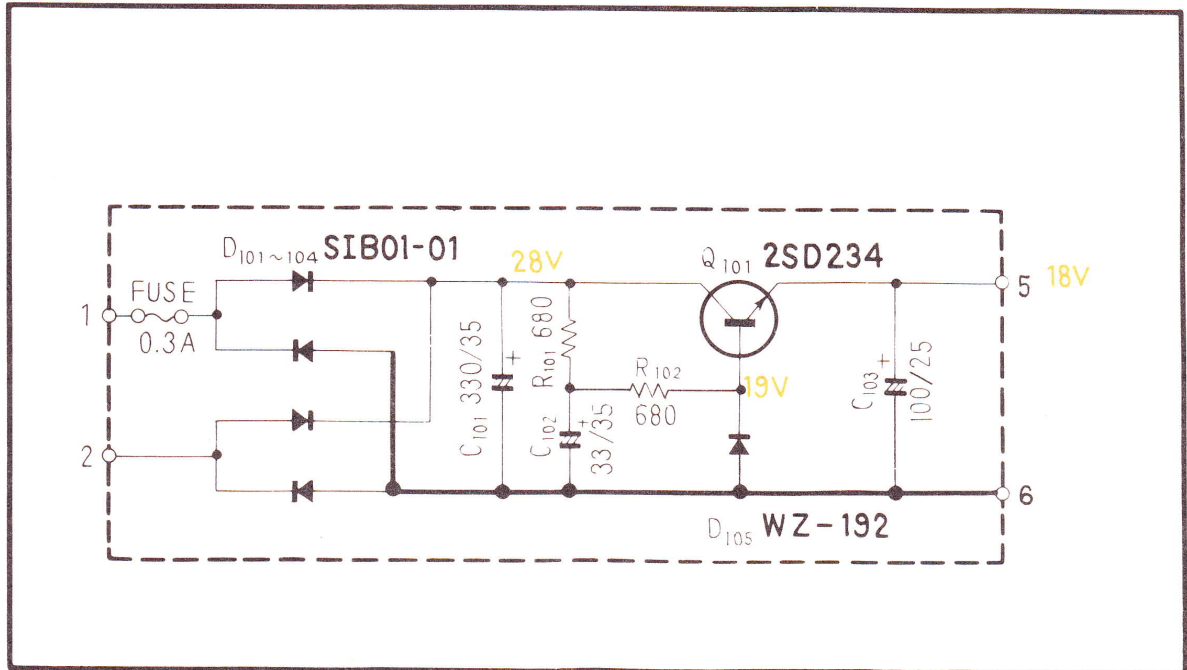

Foil Side

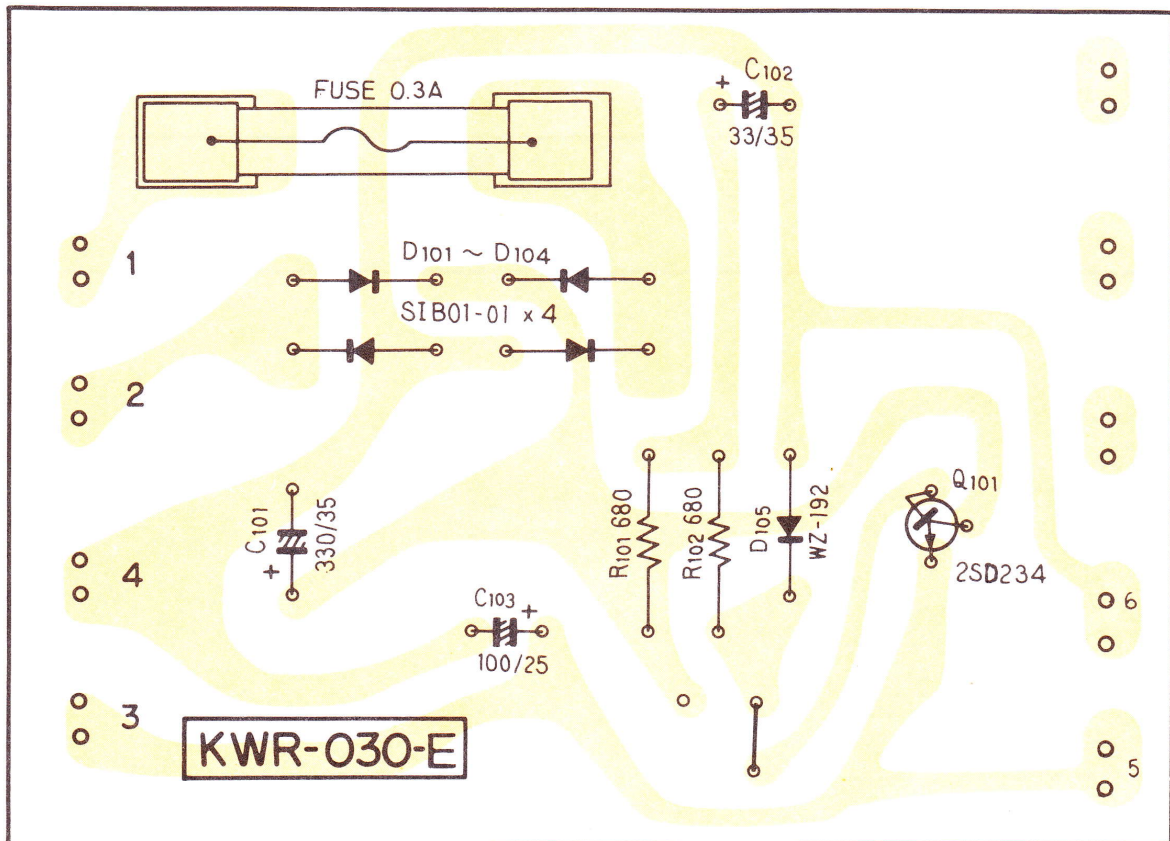

- CAPACITORS: IN μ F UNLESS OTHERWISE NOTED p: pF
- RESISTORS: IN Ω , $\frac{1}{4}$ W UNLESS OTHERWISE NOTED k: k Ω , M: M Ω

Parts List of Power Supply Circuit Assembly

CAPACITORS

Symbol	Description	Part No.
C101	Electrolytic 330 35V	CEA 331P 35
C102	Electrolytic 33 35V	CEA 330P 35
C103	Electrolytic 100 25V	CEA 101P 25

RESISTORS

Symbol	Description	Part No.
R101	Carbon film 680	RD $\frac{1}{4}$ PS 681J
R102	Carbon film 680	RD $\frac{1}{4}$ PS 681J

SEMICONDUCTORS

Symbol	Description	Part No.
Q101	Transistor 2SD234	
D101	Diode SIB01-01	
D102	Diode SIB01-01	
D103	Diode SIB01-01	
D104	Diode SIB01-01	
D105	Zener diode WZ-192	

OTHERS

Symbol	Description	Part No.
	Fuse 0.3A	E21-030-0
	Fuse holder	K91-006-0

PIONEER ELECTRONIC CORPORATION

4-1, 1-Chome, Meguro, Meguro ku, Tokyo 153, Japan

U.S. PIONEER ELECTRONICS CORPORATION

75 Oxford Drive, Moonachie, New Jersey 07074, U.S.A.

PIONEER ELECTRONIC (EUROPE) N.V.

Meir-Center Meir 21, 2000 Antwerp, Belgium

PIONEER ELECTRONICS AUSTRALIA PTY. LTD.

256-8 City Road, South Melbourne Victoria 3205, Australia

© MARCH 1975

Printed in Japan