

Service Service Service



Part I

Circuit Description

TECHNICAL SPECIFICATIONS

Input Sensitivity (Ref. Output)		Crosstalk (Minimum)	
Phono 1	2mv (Adj 1.5-18mv)	Between Modes	75dB
Phono 2	10mv (Adj 1.5-18mv)		
Aux. Tuner, Tape Play	200mv	Output Level	
Impedance		Output 1,2 Rated	2 Volts
Phono input 1,2	50K Ohms	Maximum	12 Volts
Aux, Tuner, Tape Play	100K Ohms	Record Output A,B	200mv
Tape Record Out	1K Ohms		
Pre-amp Out	600 Ohms	Controls	
Total Harmonic Distortion	0.01% (2 V Output)	Bass (50Hz)	±10dB (2dB detent)
Intermodulation Distortion	0.01% (2 V Output)	Treble (10kHz)	±10dB (2dB detent)
Signal to Noise Ratio (Minimum)		Loudness Action (-30dB)	
Phono (1.5mv input)	75dB	50Hz	±10dB
Aux. Tuner, Tape	90dB	10kHz	±4dB
Phono Overload	750mv	Filters	
Frequency Response		High Cut (10kHz)	-9dB
Phono 1,2	RIAA +0,-0.5dB	Low Cut (50Hz)	-9dB
Aux, Tuner, Tape	10-45kHz, -1.0dB	Muting	-20dB
Separation (Minimum)		Power Supply	120/240 V 50/60Hz
Phono 1,2	55dB	Power Consumption	22 watts
Aux, Tuner, Tape	55dB		

Description des circuits Schaltungsbeschreibung Kredsløbsbeskrivelse Kretsbeskrivelse Kretsbeskrivning Toimintaselostus Descrizione del circuito Description del circuito



Subject to modification
4822 725 12762
Printed in The Netherlands

PHILIPS

Phono Pre-Amp Assembly

The Phono Pre-Amp assembly receives, and when necessary amplifies, the input signals to the unit. The input circuits are designed with a high input impedance, and a low output impedance. This prevents loading of the source and provides a high current output to the next stage to help eliminate hum and noise.

The input circuits for the Tuner, Aux., and Tape Play input jacks consist of a capacitively coupled emitter follower, whose output is applied to the switching circuits.

The input circuit for each channel of the Phono 1 and Phono 2 jacks is identical. This circuit (a differential input, complementary output amplifier) provides a high input impedance and a low output impedance, as did the emitter followers mentioned above. However, since the signal level at the phono jacks may be extremely low, depending upon the cartridge being used, amplification may also be necessary.

The operation of this circuit is as follows, using the right channel of the Phono 1 input. The signal from the input jack is coupled through C201 and R209 to the base of Q201. R201 and R205 provide the input impedance of approximately 47K ohms, while R209, C257, and C205 form an RF suppression network. Capacitor, C201, keeps any DC potential from being present at the input jack, but passes the input audio signal. Q201 and Q205 form a differential amplifier. The gain and frequency response of this amplifier are determined by the feedback networks in the base circuit of Q205. By varying the amount of feedback present at the base of Q205, R225 establishes the overall gain of the amplifier, and therefore, the sensitivity of the circuit.

The output of the differential amplifier is direct coupled from the collector of Q201 to the base of the driver, Q209. The output at Q209 collector is applied to the bases of Q213 and Q217 which form a complementary symmetry push-pull amplifier. The output of the complementary symmetry amplifier is taken from the junction of R253 and R257. It is then coupled through C229 and pin 2 of P/J214 to the Selector Switch assembly. C229 passes the audio signal, but blocks any DC potential from the switching circuits, thereby eliminating any audible 'pop' during the switching operation.

Selector Switch Assembly & Tape Monitor & Mode Assembly

The switching circuits contained on the Selector Switch assembly and the Tape Monitor and Mode assembly are used to distribute the signals to the appropriate places and light the correct function and mode indicators.

The Selector Switch assembly receives the tuner, aux., and phono inputs from the Phono Pre-Amp assembly. The Function Selector switch, S201, is rotated to select which input signals will be coupled to the Tape Monitor and Mode assembly. A portion of this switch also provides a current path to light the appropriate function indicator. The Tape Play inputs are coupled directly from the Phono Pre-Amp assembly to the Tape Monitor and Mode assembly. Here, they are connected to the Tape Monitor switch, S202, along with the signals from the Selector Switch assembly. The Tape Monitor switch connects the appropriate input signals to the Tape Record jacks and K201, one of the Tape Monitor relays. Part of S202 also forms a current path to light the correct Tape Monitor indicator.

The other Tape Monitor Relay, K202, is connected to the input signals from the Selector Switch assembly. The two Tape Monitor relays are connected so that when the contacts of one are open, the contacts of the other are closed.

Contacting the Tape Monitor Touch Control changes the state of the relays. Therefore, with the Tape Monitor circuit activated K201 is energized and the signals from the Tape Monitor switch are coupled through the relay contacts to the Mode switch and on to the Volume and Filter assembly. When the Tape Monitor circuit is deactivated K202 becomes energized, and the signals from the Selector Switch assembly are now coupled through the relay contacts to the Mode switch. The Mode switch, S203, determines upon which output channel the input signals appear. The signals leaving the Mode switch are applied to the left and right channel circuits on the Volume and Filter assembly. Part of the Mode switch also provides a current path to light the correct mode indicator.

Volume and Filter Assembly

The Volume and Filter assembly establishes the level of the units output signal, and determines the balance between the right channel level and the left channel level.

Also included on the Volume and Filter assembly are circuits which change the frequency content of the signal to provide low-cut filtering, high-cut filtering, and loudness compensation.

The operation of this assembly is explained using the left channel circuits. The signal at pin 3 of P/J303 is coupled through R372 to the top of the Volume control, R325B. The signal is also supplied to the filter network in the base circuit of Q302. Due to the action of this filter network the mid-range frequencies of the signal at the base of Q302 are attenuated more than the high and low frequencies. When the Loudness control is activated, the positive potential (about 25V) at the gate of Q304 is reduced to nearly ground by saturated Q553, on the Touch Control Assembly (see Touch Control Assembly for further information). This action causes Q304, which acts as an open switch when Loudness is not activated, to now act as a closed switch. The output of the emitter follower, Q302, is now coupled through C310 and Q304 to the tap on the Volume Control, R325B. Thus, the high and low frequencies are boosted at volume settings below the tap.

From the wiper on the Volume Control, the signal is coupled through C314 to a differential amp, Q306 and Q308. The output of the differential amp is direct coupled from the collector of Q306 to the base of Q310. Being a common emitter amplifier, Q310, amplifies and inverts the signal, and applies it through C320 to the top of the Balance control, R326B. A portion of the signal at the collector of Q310 is applied as negative feedback, through R336, to the base of Q308. The divider network made up of R336 and R338 determines the amount of feedback present at the base of Q308. This in turn determines the gain of the differential amp, Q306 and Q308. Capacitor, C318, has no effect on the signal.

To allow for better filtering action, a two-stage filter is included on the Volume and Filter assembly, with Darlington amplifiers acting as buffers between stages.

With the high and low cut filters not activated, Q312 and Q318 are turned off. This condition effectively removes these transistors from the circuit, since they appear as a very high resistance. Under these conditions, the signal at the wiper of the Balance control is coupled through C322, R342, and C326 to the base of Q314. Q314 and Q316 are connected as a Darlington amplifier with its output coupled from the emitter of Q316 through C330, R358, and C334 to the base of Q320. Q320 and Q322 are also connected as a Darlington amplifier with its output coupled from the emitter of Q322 through C338 and pin 5 of P/J301 to the Tone Control assembly.

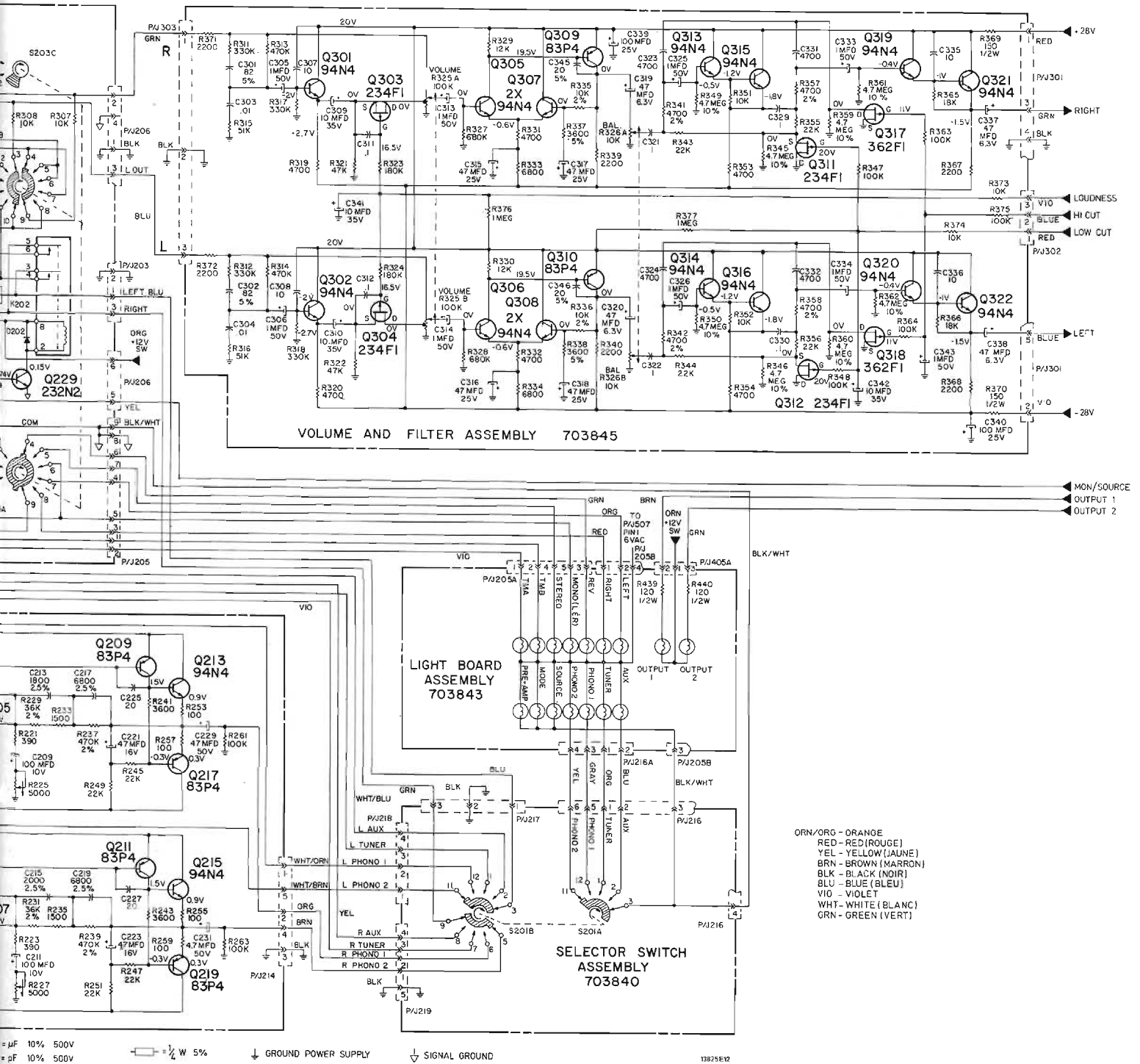

Fig. 1

amplifier while
rough Q318.

s the high cut
frequencies are

There are two methods of reverse biasing the gates of the FET's used in this assembly. The gates of the FET's used in the high cut circuitry, Q318 and Q317, are maintained at about +12V via R375, R582, D552, and the +12V switched source. The gates of the FET's used in the low cut and loudness circuits are maintained at about +20 volts via

R376 or R377, and the +28V source. If Q303, Q304, Q311, and Q312 were not biased in this manner, it would be possible for the low frequencies present in these circuits to turn on the FET's unintentionally, causing clipping and distortion. Since this problem does not exist in the high cut circuits, the higher reverse bias is not necessary.

Touch Control Assembly

The Touch Control assembly acts as a switching network for all the front panel touch-controls except Power (see Power Supply Assembly for information on the Power touch-control circuit). Since the switching circuits on this assembly are nearly identical only the circuit which activates the High Cut filter will be explained. In this circuit Q552 represents the switch used to activate the High Cut filter. As with any switch, Q552 is either open (cut-off) or closed (saturated). The purpose of the Touch Control logic circuits is to make it possible to change the conduction of the switching transistor, Q552, by means of a touch-control. The main components used to perform this function are; Q542, which acts as a momentary switch; IC541, four Schmitt trigger nand gates; and IC544, a dual flip-flop. Separate 12V sources are used by the components in this circuit to maintain the state of the logic when the unit is switched off, as explained in the Power Supply Assembly section. The inputs to each nand gate are tied together so that when they receive a low potential, (about 5V), the output of the nand gate will go high (about 12V). Under all other conditions the output of the nand gate is low, (near ground). The flip-flop is connected so that the state of its output (high or low) is reversed each time it receives a high input.

When the High Cut circuit is not activated, Q542 is turned off because of the open touch-control in its base circuit. The input to IC541, (pins 8 and 9) is about +12V, via R562, R544, R592 and the +12V Aux. source. The output of IC541 (pin 10), and the input of IC544, (pin 3), are low, near ground potential. The output of IC544 (pin 1) is low, and keeps Q552 cut-off. With Q552 cut-off there is no current path for D552, the High Cut Filter indicator, therefore, it remains unlit, indicating that the High Cut filter circuit is not activated. With no current flowing through Q552, its collector voltage remains near +12 volts. This voltage reverse biases the FET's, Q317 and Q318, in the High Cut filter circuits, thereby keeping the circuits deactivated.

By contacting the High Cut Filter touch-control, a bias network (R543, R594, and the resistance of the finger) is formed for Q542. The transistor becomes turned-on, dropping its emitter voltage toward ground. This low potential at the emitter of Q542 is coupled through the de-bounce circuit, (D542, C542, and R562) to the input of IC541, (pins 8 and 9). The de-bounce circuit is designed to keep the switching circuit from being activated twice when firm contact with the touch-control is not made. By 'brushing' over the touch-control, Q542 may be rapidly turned on and off several times. The 'de-bounce' circuit integrates the rapid changes in the Q542 emitter voltage caused by this condition, and applies a more constant potential to the input of IC541, causing it to change states only once. When the inputs to IC541 go low, the output (pin 10) goes high, (about 12V). This high potential is direct coupled to the input (pin 3) of IC544, causing its output (pin 1) to change states. Since the output was low (near ground), it now becomes high and remains there until IC544 receives another high input. The high output at pin 1 of IC544 drives Q552 into saturation placing its collector voltage near ground and forming a current path for the High-Cut filter indicator, D552. With its anode tied to the +12V switched source and its cathode tied to ground through R582 and Q552; the LED, D552, lights to indicate that the High Cut filter circuit is now activated. The near ground potential at the collector of Q552 is also applied to the gates of Q317 and Q318, on the Volume and Filter assembly. This action switches the FET's to the on state, providing a low impedance path between Source and Drain, thereby, activating the High Cut filter circuits by placing bypass capacitors C314, C332, C331, and C313 into the circuit.

When the finger is removed from the touch-control, Q542 returns to cut-off, the input to IC541 (pins 8 and 9) returns to a high state, and the output of IC541 (pin 10) returns to its low state. Since the output of the flip-flop, IC544, changes states only when its input goes high the new conditions will have no effect upon it. Therefore, pin 1 of IC544 will remain high keeping Q552 saturated and the High Cut filter circuits activated.

By contacting the touch-control a second time, another high input is applied to IC544 reversing the state of its output to a low potential (near ground). This action cuts-off Q552 whose collector voltage again rises to +12V, turning off Q317 and Q318 on the Volume and Filter assembly, thereby deactivating the High Cut circuits. With Q552 cut-off, a current path for D552 no longer exists. The High Cut filter indicator, D552, therefore, stops conducting and extinguishes, indicating that the High Cut filter circuits are deactivated.

Although all of the circuits on the Touch Control assembly operate basically like the one described above, there are some minor differences. For reasons described in the Volume and Filter Assembly section, the gates of the FET's used in the Loudness and Low Cut filter circuits are reverse biased at about +20V when the circuits are deactivated. Therefore, this +20V potential is present at the collectors of Q551 and Q553 when they are cut-off. Even though this differs from the collector voltages of Q552 and Q554 thru Q558 the switching action of these circuits remains the same.

Another difference exists in the connection of switching transistor, Q558. Switching transistors Q551 thru Q557 activate their associated circuits with the low potential present at their collectors when they become saturated. Since the Mute circuit must be activated by a high potential, its control line is connected to the base of Q558 rather than the collector. Therefore, when Q558 becomes saturated the high potential at its base activates the Mute circuit, while the low potential at its collector forward biases the Mute indicator, D558.

Tone Control Assembly

The input signal to the Tone Control assembly is received from the Volume and Filter assembly. Since the Volume and Filter assembly contains filter circuits, some alterations to the frequency content of the signal may have already taken place. For the purpose of this circuit description the input signal to the Tone Control assembly will be considered flat, (all frequencies in the signal amplified approximately the same amount).

The circuitry on the Tone Control assembly is used to vary the frequency content of the signal being amplified. Also included on this board is the Tone Defeat circuitry. The Bass and Treble controls work by changing the level of the low and high frequencies present in the signal which is applied to dual operational amplifier, TC451. With the Bass and Treble controls set at the flat (center) position, the signal at each input to IC451 will consist of low, mid-range, and high frequencies at approximately the same relative level. By varying the Bass control it is possible to raise or lower the level of the low frequencies in the signal at its wiper. This is done by attenuating the low frequencies more or less than the mid-range frequencies. The Treble control works basically the same as the Bass control except it varies the level of the high frequencies in the signal. The Op Amp, IC451, provides the gain necessary to offset the attenuation caused by the Bass and Treble controls. The Tone Defeat circuit removes the Bass and Treble controls

from the input to the Op Amp and replaces them with a set resistance. Since this resistance does not vary the level of different frequencies within the signal its effect is the same as placing the Bass and Treble controls to the flat position. This allows the listener to compare a flat signal to a signal with tone compensation without changing the Bass and Treble control settings. The control lines for the FET's used in the Tone Defeat circuit employ delay networks consisting of R474, R475, D451 and C471; and R476, R477 and C472. These delay circuits cause a make-before-break situation when the Tone Defeat circuit is activated. This method of switching eliminates the possibility of an audio 'pop' occurring at the speakers.

Since the left and right channels on the Tone Control assembly are identical, only the left channel will be discussed. The flat signal is coupled onto the board at pin 3 of P/J453. From here it is applied to the Treble control, R452B, and through R454 to the Bass control, R451B. A portion of the signal is also coupled through R482 to the source of Q454. Assuming that the Tone Defeat circuit is not activated, Q454 is turned off, blocking this portion of the signal from the input of IC451B. Since we are assuming that the Tone Defeat circuit is not activated, Q452 must be turned on. This allows the signal at the junction of R458 and C456 to be coupled through Q452 and C470 to the input of the Op Amp IC451B. The frequency content of the signal at the junction of R458 and C456 is determined by the settings of the Bass and Treble controls. Although both controls attenuate all the frequencies in the signal, the Bass control can be set to attenuate the low frequencies more or less than the other frequencies and the Treble control can be set to attenuate the high frequencies more or less than the other frequencies. This is accomplished by changing the RC networks contained in the Bass and Treble circuits as the wipers are moved from one end of the controls to the other. The tone compensated signal applied to pin 6 of the Op Amp, IC451B, is amplified, inverted, and then coupled from pin 7, through R466, L452, C462, and R468 to pin 1 of P/J451. A portion of the signal at pin 7 of IC451B is fed back to pin 6 via R480 and C466. This feedback network determines the gain/frequency characteristics of the Op Amp. The filter formed by R466, C458, L452, C462, C460, R468, and R470 is used to reduce the high frequency noise in the output, and has no effect at audio frequencies.

When the Tone Defeat circuit is activated, the input to IC451B is received from pin 3 of P/J453, via R482 and Q454. The signal at the junction of R458 and C456 is blocked by Q452, which is turned off. Since the signal now applied to the Op Amp has had no tone compensation, the output of the amp is the same as if the Bass and Treble controls were set to the 'flat' position with the Tone Defeat circuit deactivated.

The Tone Defeat circuit is deactivated when the potential from the Touch Control assembly (pin 6 of P/J452) is high, about +12V. This potential is applied to the gates of Q453 and Q454 through D451, R474 and R475 keeping these FET's turned off. The high potential at pin 6 is also applied to Q455 via R473 biasing it on and keeping its collector voltage near ground. This near ground potential is applied to the gates of Q451 and Q452, via R477, thus keeping these FET's turned on. When the circuit is activated the potential at pin 6 of P/J452 drops to near ground through the action of the Touch Control circuits.

This near ground potential is applied to the gates of Q453 and Q454, turning them on. The near ground potential is also applied to the base of Q455, cutting the transistor off. This action causes the collector voltage of Q455 to rise towards the +28V source through R476 and R471. The positive collector voltage of Q455 is applied to the gates of Q451 and Q452 turning these FET's off. Due to the charge/discharge characteristics of C472, R477, and R476

in the gate circuit of Q451 and Q452, these FET's will turn on quickly when Tone Defeat is deactivated and turn off slowly when Tone Defeat is activated. Likewise, due to the charge/discharge characteristics of C471, D451, R471, and R475 FET's Q453 and Q454 will turn on quickly when Tone Defeat is activated and turn off slowly when Tone Defeat is deactivated. This action, which is the same as a make-before-break mechanical switch, assures that an input signal is always present at the Op Amps, which in turn prevents an audio 'pop' during the switching operation.

Headphone/Output Amplifier Assembly

The Headphone/Output Amplifier assembly provides the final stages of amplification to the signal before it is coupled to the output and headphone jacks. Also included on the Headphone/Output Amplifier board is the Mute circuit. When activated, this circuit reduces the level of the output signal by 20db.

Since the circuits for the left and right channels are identical, only the left channel will be discussed. The signal at pin 1 of P/J405 is received from the Tone Control Assembly. From pin 1 the signal is capacitively coupled through C402 to the base of Q402. Q402 and Q404 form a differential amplifier whose gain and frequency response are determined by the feedback network in the base circuit of Q404. The output of the differential amplifier is direct coupled from the collector of Q402 to the base of Q408, a common emitter driver, where it is amplified and inverted. The output from Q408 collector is applied to the bases of Q410 and Q412. These transistors are arranged as a complementary symmetry push-pull amplifier, with the output being taken from the junction of their emitter resistors, R424 and R426. The output signal is coupled through R430 to the headphone jack, and through C416 and R428 to the output relays. As long as the relays are not energized there will be no signal present at the output jacks. Since a separate relay is used for each set of output jacks, it is possible to activate either or both sets by energizing the correct relays. As an example, the Output 1 relay is energized by contacting the Output 1 touch control. Due to the switching action of the Touch Control assembly, pin 2 of P/J401 changes from a positive potential (about +12V) to a near ground potential. This action forward biases D405 and Q413 causing conduction through the Output 1 relay coils and closing the contacts that couple the signal to the Output 1 jacks. Q413, C419 and R435 are placed in the supply line of the solenoids to delay their energizing when the unit is switched on. This is necessary due to the transient voltages present in the amplifier circuits immediately after it is switched on. If the output solenoids were allowed to energize immediately, the transient voltages would be amplified causing objectionable noise from the speakers.

The Mute circuit reduces the signal level at the output by 20db. This is accomplished by changing the feedback circuit of the differential amp, Q402 and Q404. When the Mute circuit is not activated the voltage coupled from the Touch Control assembly to the gate of Q406, via R436 and Pin 1 of P/J401, is near ground potential. This keeps Q406

turned on, causing it to act as a low resistance, effectively shunting R412 in the feedback divider network of Q404. This shunting action places a small amount of negative feedback at the base of Q404, thereby establishing the stage gain under unmuted conditions.

When the Mute circuit is activated, the potential applied to the gate of Q406 rises to some positive level. This action biases Q406 off, thereby removing the shunt across R412 and effectively raising the resistance of the feedback

divider network of Q404. This action increases the negative feedback at the base of Q404, which in turn lowers the stage gain and mutes the signal.

Power Supply

The Power Supply assembly develops the DC voltage sources needed by the circuits, as well as the 6 VAC source needed by the function lamps. The +28V and -28V sources supply power to the amplifiers, while the +12V Switched source supplies power to the relay circuits, the output lamps, the indicator LED's, and the Nand Gates, (IC541 & IC542).

The +12V Auxiliary source supplies power for the On/Off Relay, K501, and its associated switching circuitry. This source also supplies voltage to the flip-flops and darlington switches on the Touch Control assembly.

The +12V Aux. source is present whenever the unit is plugged in and the Master Power switch, S501, is on. The other sources are developed only when the Power Touch Control, on the front panel, is activated along with the Master Power switch. This arrangement allows the unit (Master Power switch 'On') to be kept switched on and off with the Power Touch Control without changing the states of the flip-flops on the Touch Control assembly. Therefore when the unit is switched off and on by the Power Touch Control, those functions that were activated when the unit was switched off, will again be activated when the unit is switched back on.

The following is a description of the operation of the Power Supply circuits. When the unit is plugged in, and the Master Power switch is turned on, mains supply is applied to the primary of T502 where it is stepped down to a low AC voltage at the secondary. The low AC voltage from the secondary is half wave rectified by D506 and filtered by C510. The DC level at the positive side of C510 is regulated at +12V by zener, Z501. C509 is in parallel with D506 to protect it from noise spikes.

This +12V Auxiliary source is coupled off the board at pin 1 of P/J505. It is also applied to the emitter of Q502, to the base of Q502 (through R503), and to the collector of Q501 (through K501). Since the open Power Touch Control does not allow base current in Q502, the transistor is cut-off. With Q502 cut-off, Q501 has no source of forward bias and is also cut-off. Since Q501 is cut-off it will not develop collector current, therefore, no current will flow through the coil of K501, the On/Off relay. The On/Off relay, K501, is a bistable relay employing a mechanical latch which opens or closes the contacts each time the relay is energized. Therefore, when the relay is energized, with the contacts initially open, the latch will close the contacts and keep them closed even after the relay again becomes de-energized. To re-open the contacts the relay must be energized a second time.

By contacting the Power Touch control, Q502 is biased on via R503, R515, and the resistance of the finger across the Touch control. When Q502 turns on, its collector voltage becomes positive and turns on Q501. Since the collector current of Q501 must flow through the coil of K501 to reach the +12V Aux. source, the relay becomes energized reversing the state of the contacts. Assuming that the unit is being switched on, the contacts will be closed.

With the contacts of K501 closed, mains supply is applied to the primary of T501.

Stepped-down AC voltages at the secondary windings of T501 are used to develop the sources. The main secondary

winding, with its center-tap grounded, is connected to a full-wave bridge rectifier which develops the +28V and -28V sources. Both of these sources employ filters and series regulators, Q503 and Q504.

The other secondary winding is grounded at one end, while the other end is applied to a half-wave rectifier, D505. A center-tap on this secondary winding provides 6 VAC for the function lamps. The output of the half-wave rectifier is filtered and becomes the +12V switched source. This source is applied through R504, and pin 4 of P/J507 to forward bias the Power Indicator LED, D559, whenever the unit is switched on. It is also coupled off the board at pin 3 of P/J505.

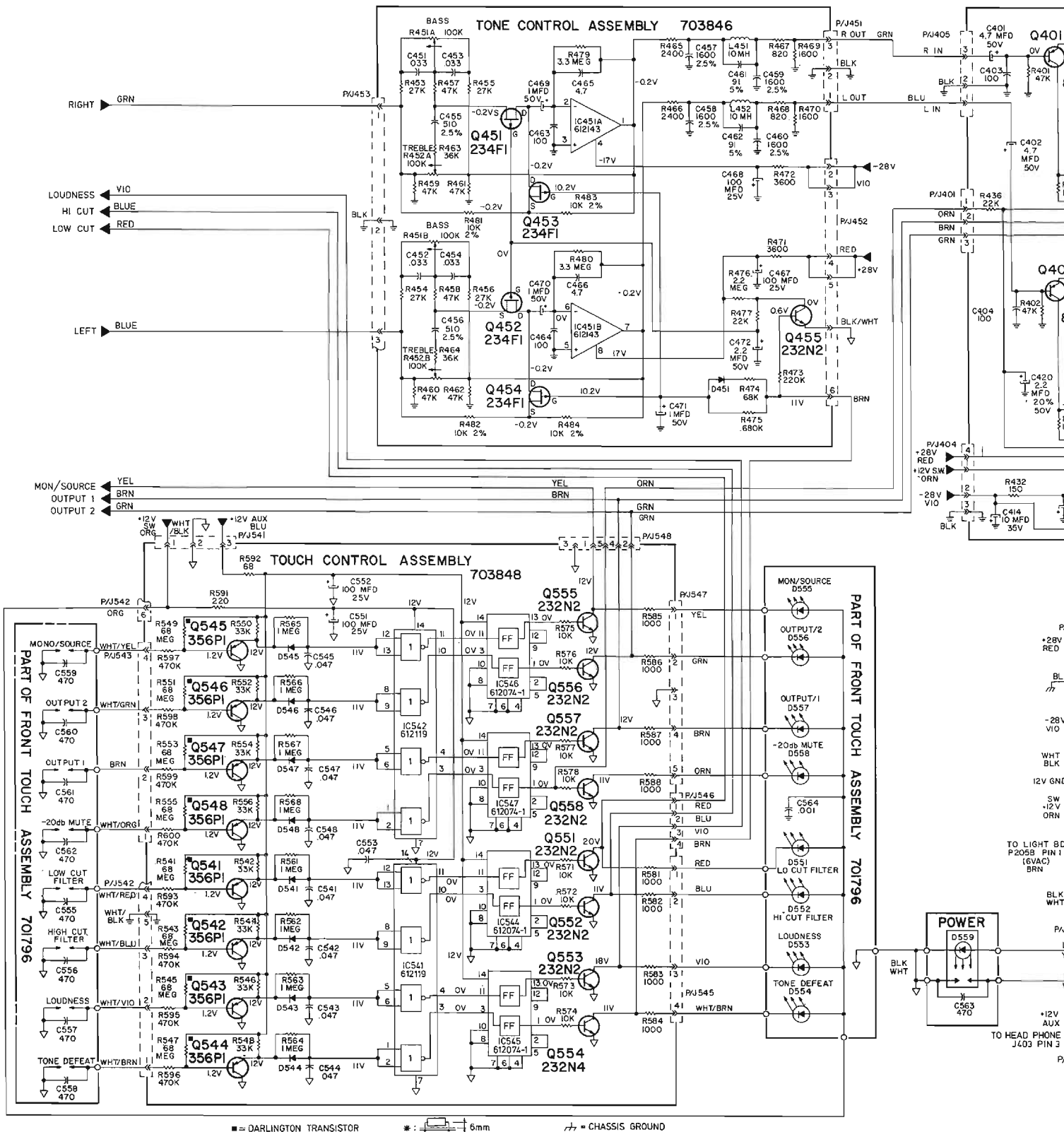

Fig. 2

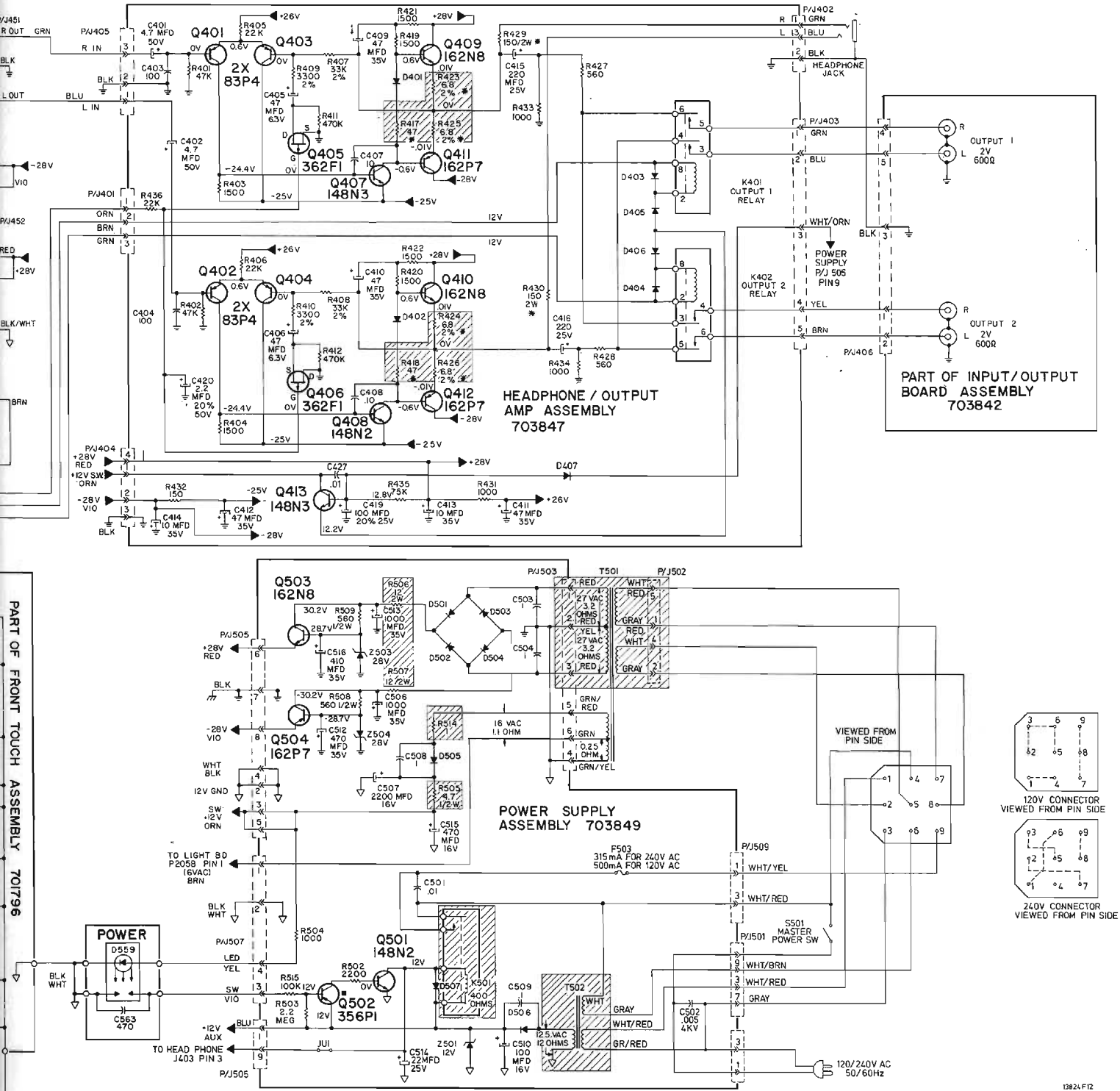
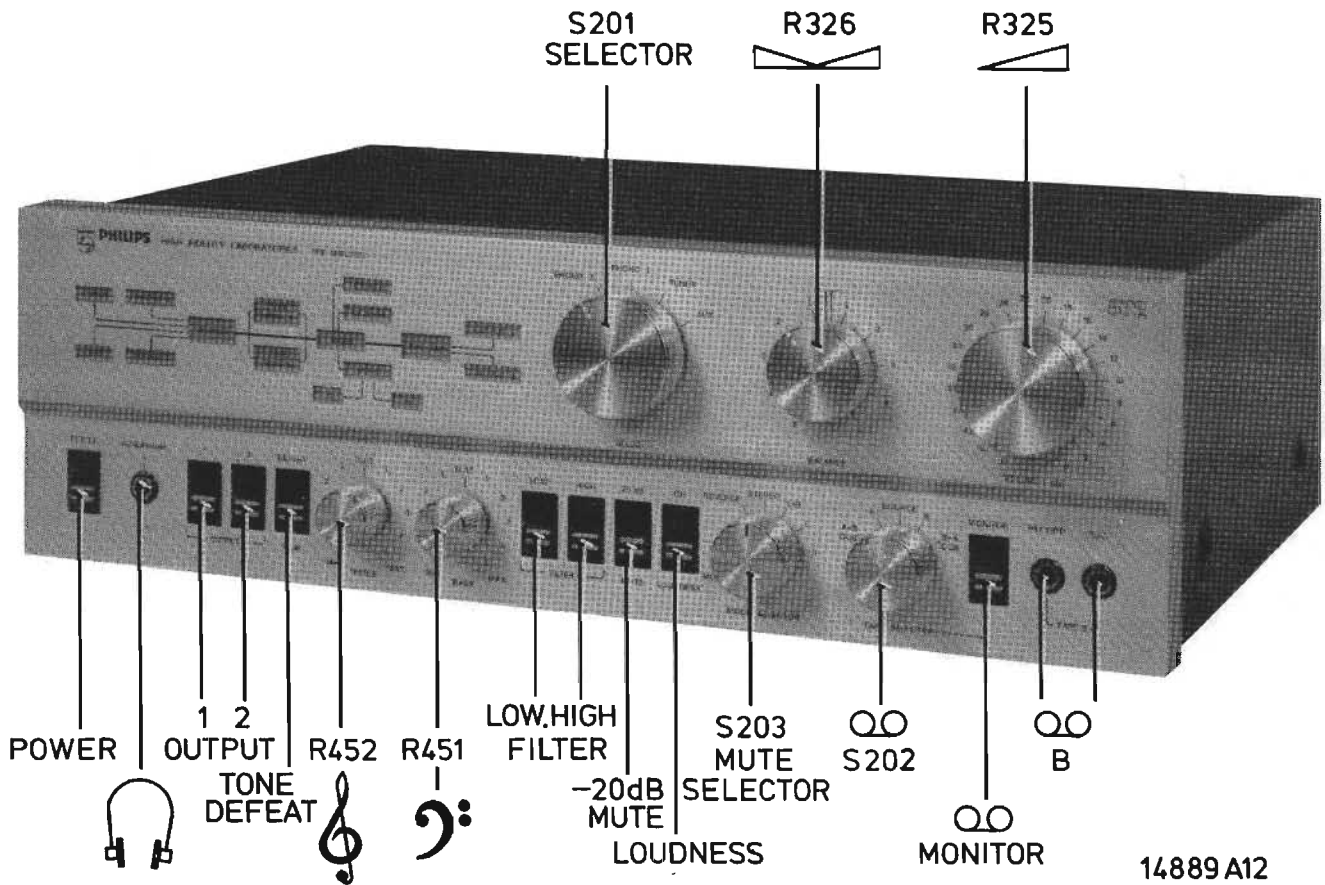

Fig. 2

Service Service Service

PART 2

Service Manual



14889 A12

Fig. 1

GB

Safety regulations require that the set be restored to its original condition and that parts which are identical with those specified, be used.

Documentation Technique Service Dokumentation Documentazione di Servizio Huolto-Ohje Manual de Servicio Manual de Servicio



Subject to modification
4822 725 12764
Printed in The Netherlands

PHILIPS

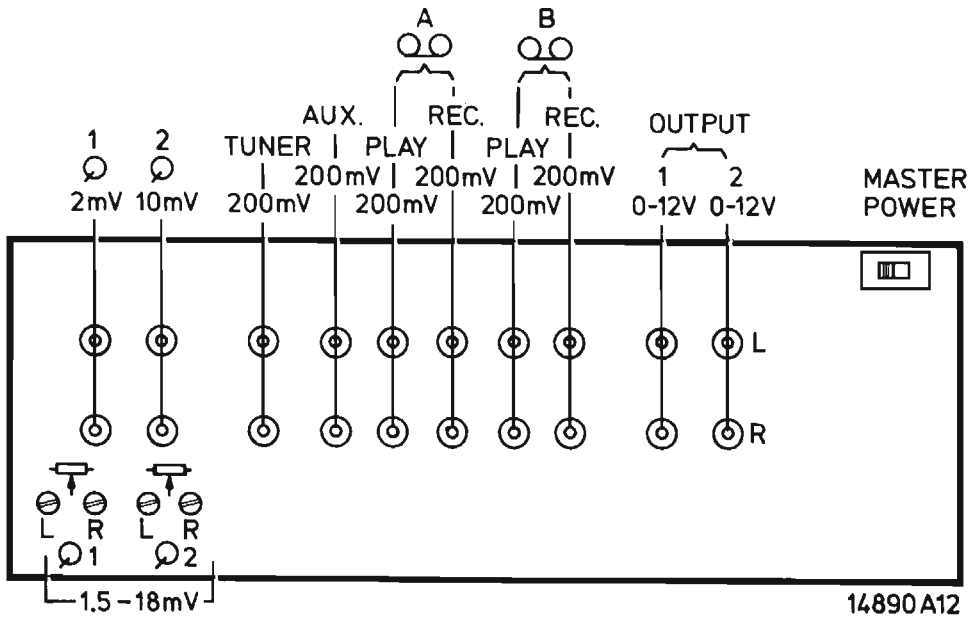

Fig. 2

TECHNICAL SPECIFICATIONS

Input Sensitivity		Crosstalk (Minimum)	
Phono 1	2mv (Adj 1.5-18mv)	Between Modes	75dB
Phono 2	10mv (Adj 1.5-18mv)		
Aux. Tuner, Tape Play	200mv	Output Level	
		Output 1,2 Rated	2 Volts
Impedance		Maximum	12 Volts
Phono input 1,2	50K Ohms	Record Output A,B	200mv
Aux, Tuner, Tape Play	100K Ohms		
Tape Record Out	1K Ohms	Controls	
Pre-amp Out	600 Ohms	Bass (50 Hz)	±10dB (2dB detent)
Total Harmonic Distortion	0.01% (2 V Output)	Treble (10 kHz)	±10dB (2dB detent)
Intermodulation Distortion	0.01% (2 V Output)	Loudness Action (-30 dB)	
Signal to Noise Ratio (Minimum)		50 Hz	±10dB
Phono (1.5mv input)	75dB	10 kHz	±4dB
Aux. Tuner, Tape	90dB	Filters	
Phono Overload	750mv	High Cut (10 kHz)	-9dB
		Low Cut (50 Hz)	-9dB
Frequency Response		Muting	-20dB
Phono 1,2	RIAA +0,-0.5dB		
Aux, Tuner, Tape	10-45kHz, -1.0dB	Power Supply	120/240 V 50/60Hz
Separation (Minimum)		Power Consumption	22 watts
Phono 1,2	55dB		
Aux, Tuner, Tape	55dB		

CHASSIS IDENTIFICATION

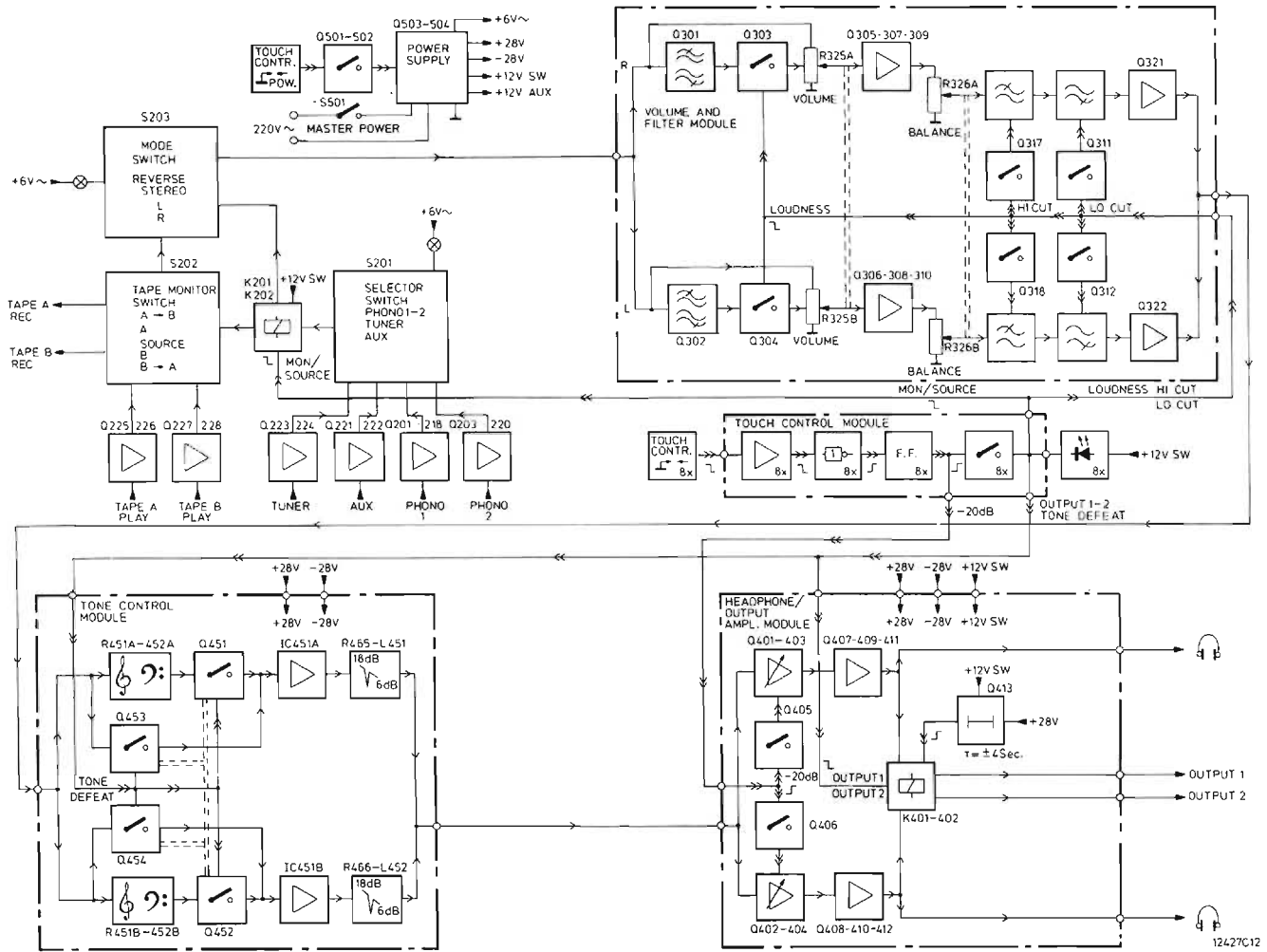
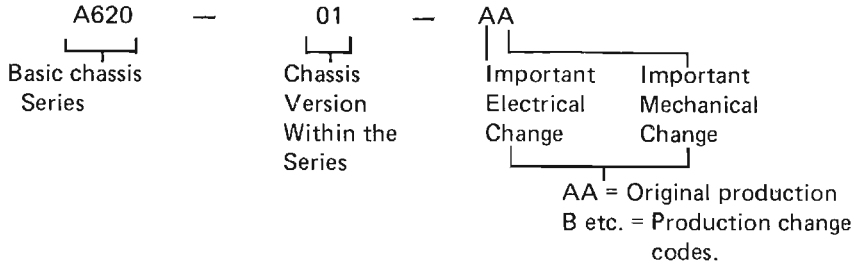

Fig. 3

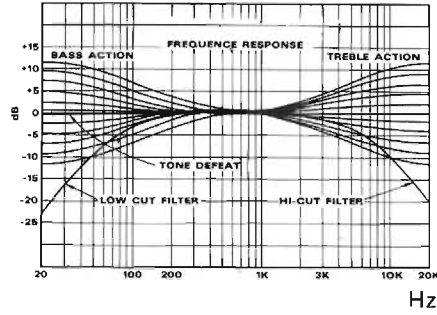
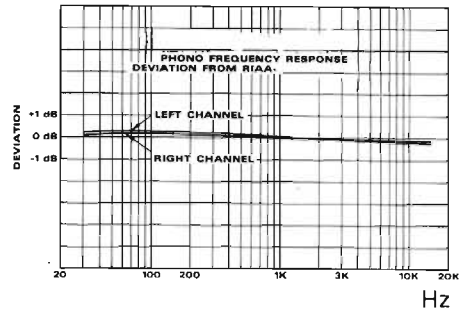
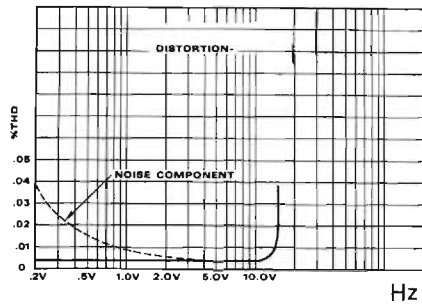
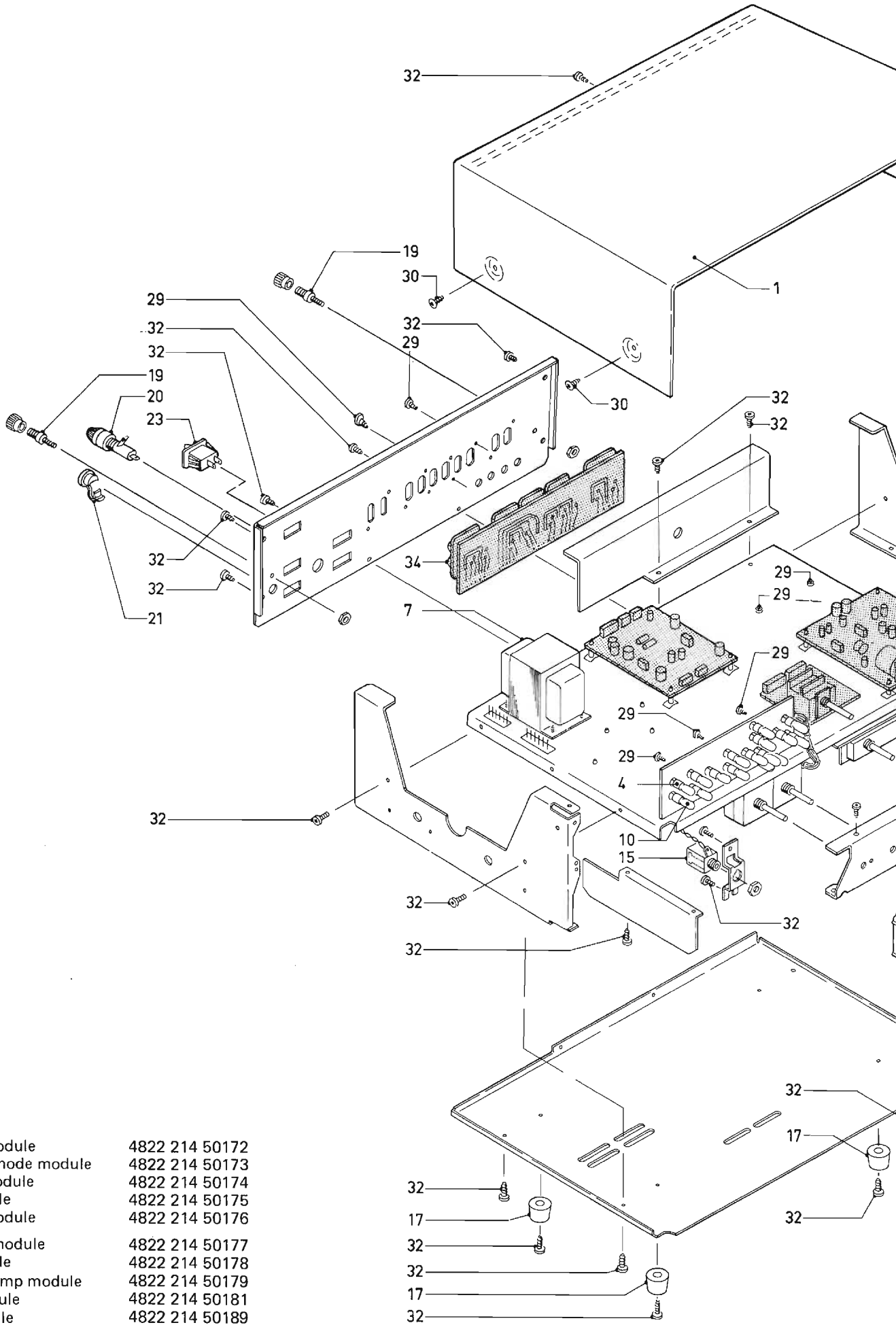

Fig. 4

<p>3 Pin 4822 267 40294 4 Pin 4822 267 40295 5 Pin 4822 267 40296</p> <p>4822 268 10118</p>	<p>2 Pin 4822 267 50269 4 Pin 4822 167 40271</p>
<p>3 Pin 4822 267 40317 4 Pin 4822 267 40297 5 Pin 4822 267 40298 6 Pin 4822 267 50248 9 Pin 4822 267 50249 10 Pin 4822 267 50264</p>	<p>3 Pin 4822 267 40272 4 Pin 4822 267 40273 5 Pin 4822 267 40274 6 Pin 4822 267 50244 7 Pin 4822 267 50245 9 Pin 4822 267 50246</p> <p>4822 268 10113</p>
<p>4822 267 50243</p> <p> ϕ 2.2 mm 4822 268 10114 ϕ 3 mm 4822 268 10121 ϕ 2.2 mm 4822 268 20071 ϕ 3 mm 4822 268 20073 </p>	<p>3 Pin 4822 267 40291 4 Pin 4822 267 40292 5 Pin 4822 267 40293 6 Pin 4822 267 50247 7 Pin 4822 265 30154 8 Pin 4822 267 50263</p>
<p>3 Pin 4822 267 40275 4 Pin 4822 267 40276 5 Pin 4822 267 40289</p>	<p>3 Pin, 1" 4822 265 40137 3 Pin, 1 1/4" 4822 265 30141 4 Pin, 1" 4822 265 30138 5 Pin, 1" 4822 265 30139 5 Pin, 1 1/4" 4822 265 30142 6 Pin, 1" 4822 265 40128 6 Pin, 1 1/4" 4822 265 40136 7 Pin, 1" 4822 265 30156 8 Pin, 1/2" 4822 265 30151 8 Pin, 1" 4822 265 40135</p>
<p>2 Pin 4822 265 30152 4 Pin 4822 265 30136 9 Pin 4822 265 30153</p>	<p>3/4" 4822 268 10116</p>
<p>8 Pin 4822 265 30155</p>	<p>5/8" 4822 268 10117</p>

Fig. 5



- Function selector module 4822 214 50172
- Tape monitor and mode module 4822 214 50173
- Input connector module 4822 214 50174
- Light display module 4822 214 50175
- Phono pre - amp module 4822 214 50176
- Volume and filter module 4822 214 50177
- Tone control module 4822 214 50178
- Headphone / pre - amp module 4822 214 50179
- Touch control module 4822 214 50181
- Power supply module 4822 214 50189

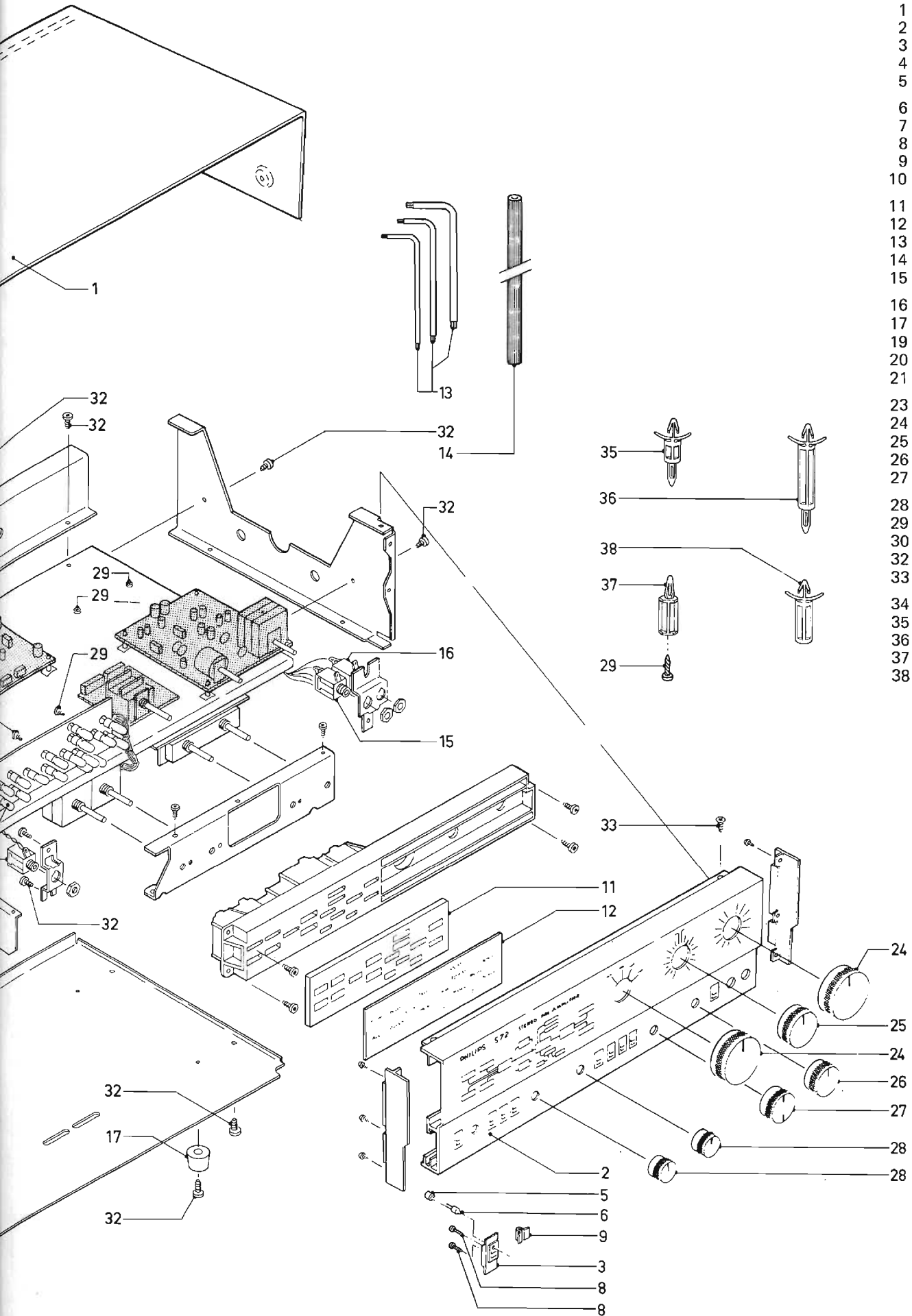

- 1 4822 426 90051
- 2 4822 459 50236
- 3 4822 276 10676
- 4 4822 255 20084
- 5 4822 256 90231
- 6 4822 130 30999
- 7 4822 146 40241
- 8 4822 502 11053
- 9 4822 404 20249
- 10 4822 134 40354
- 11 4822 459 50235
- 12 4822 454 10574
- 13 4822 395 50132
- 14 4822 395 90098
- 15 4822 267 30294
- 16 4822 267 30293
- 17 4822 462 71098
- 19 4822 267 30295
- 20 4822 256 40051
- 21 4822 325 50117
- 23 4822 277 10426
- 24 4822 413 50947
- 25 4822 413 50948
- 26 4822 413 40762
- 27 4822 413 50949
- 28 4822 413 30724
- 29 4822 502 30145
- 30 4822 500 10191
- 32 4822 502 30144
- 33 4822 502 30102
- 34 4822 268 20072
- 35 4822 535 91089
- 36 4822 535 91091
- 37 4822 535 91092
- 38 4822 535 91093

Fig. 6

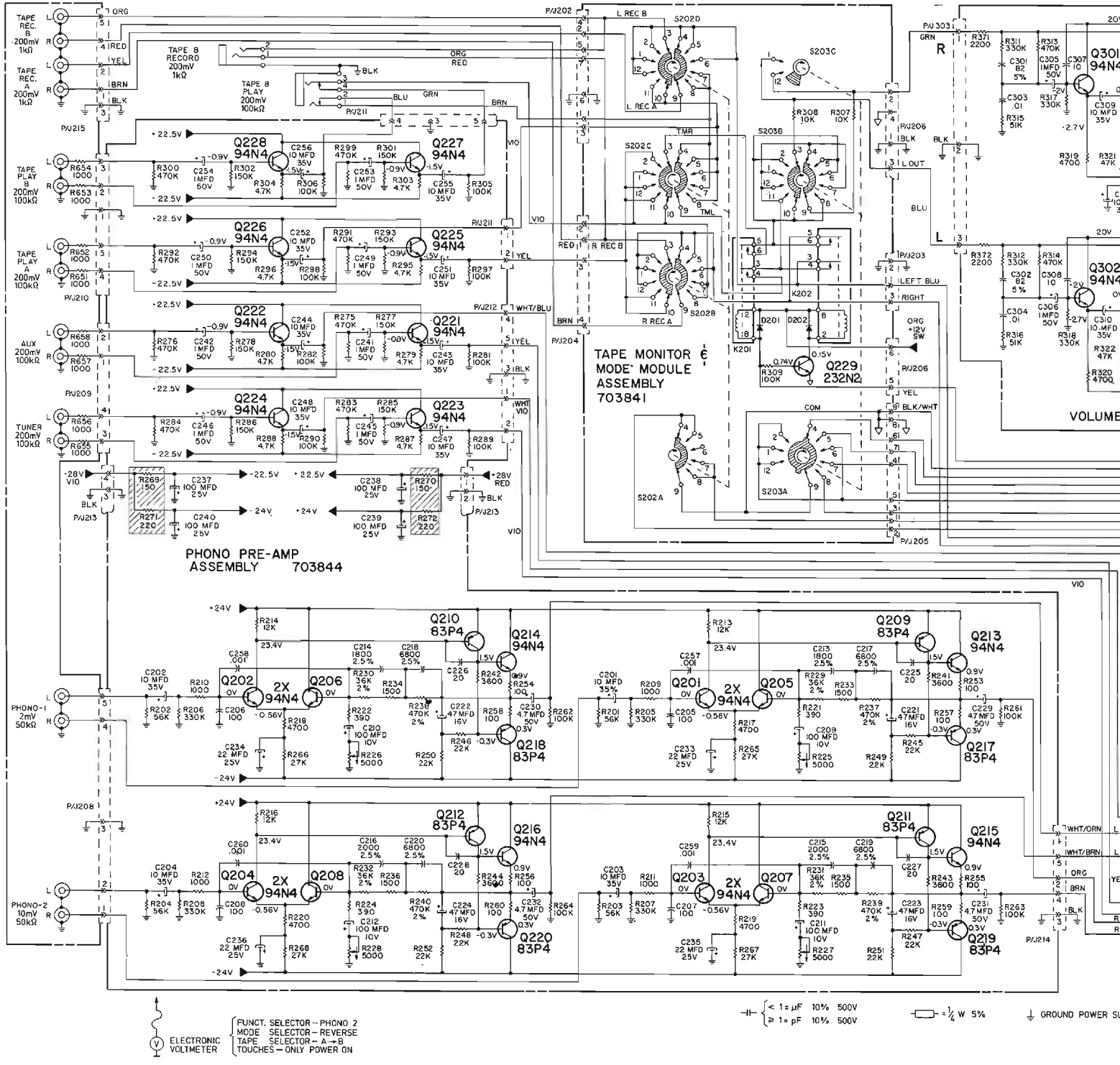

Fig. 7

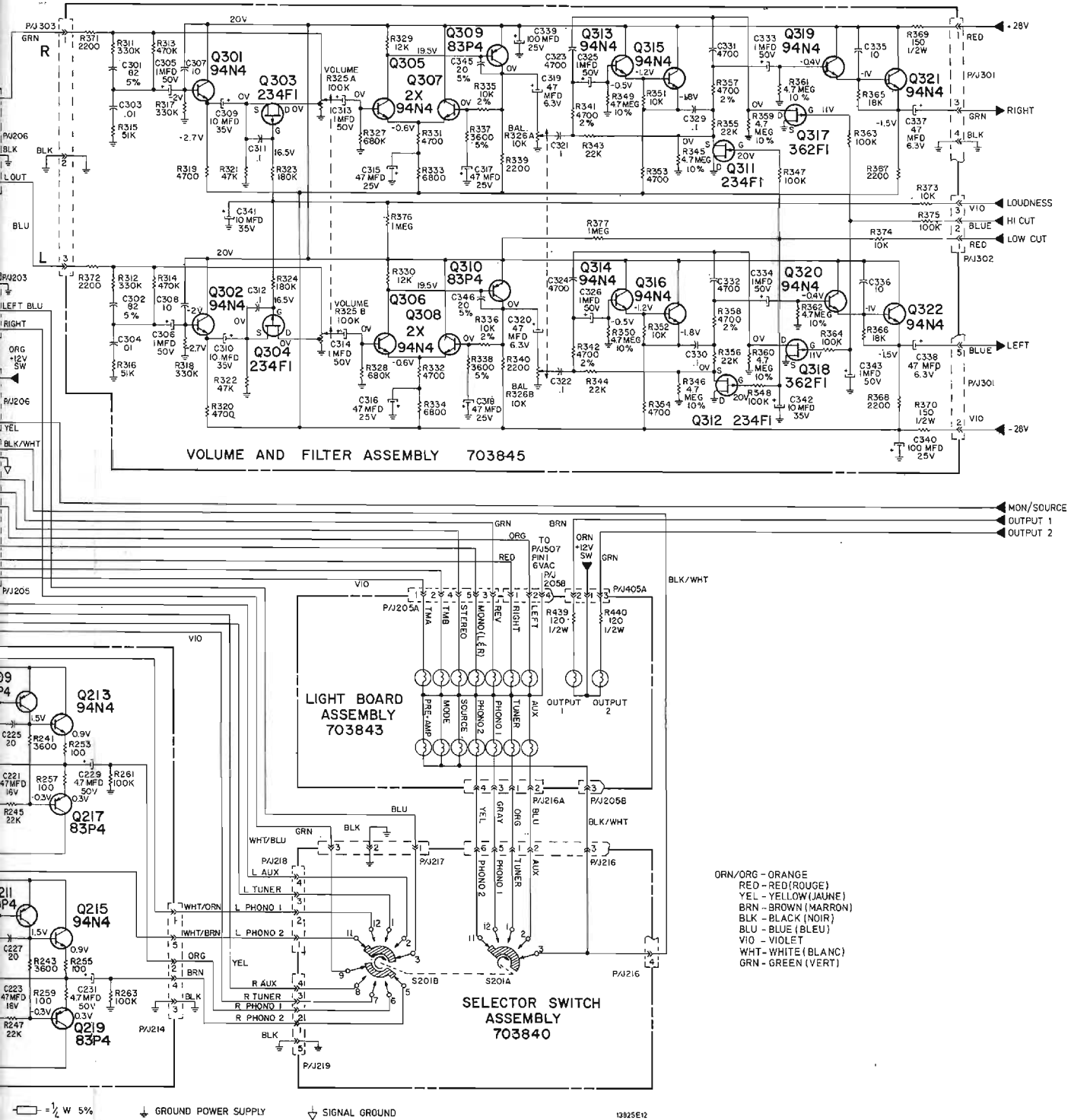

Fig. 7

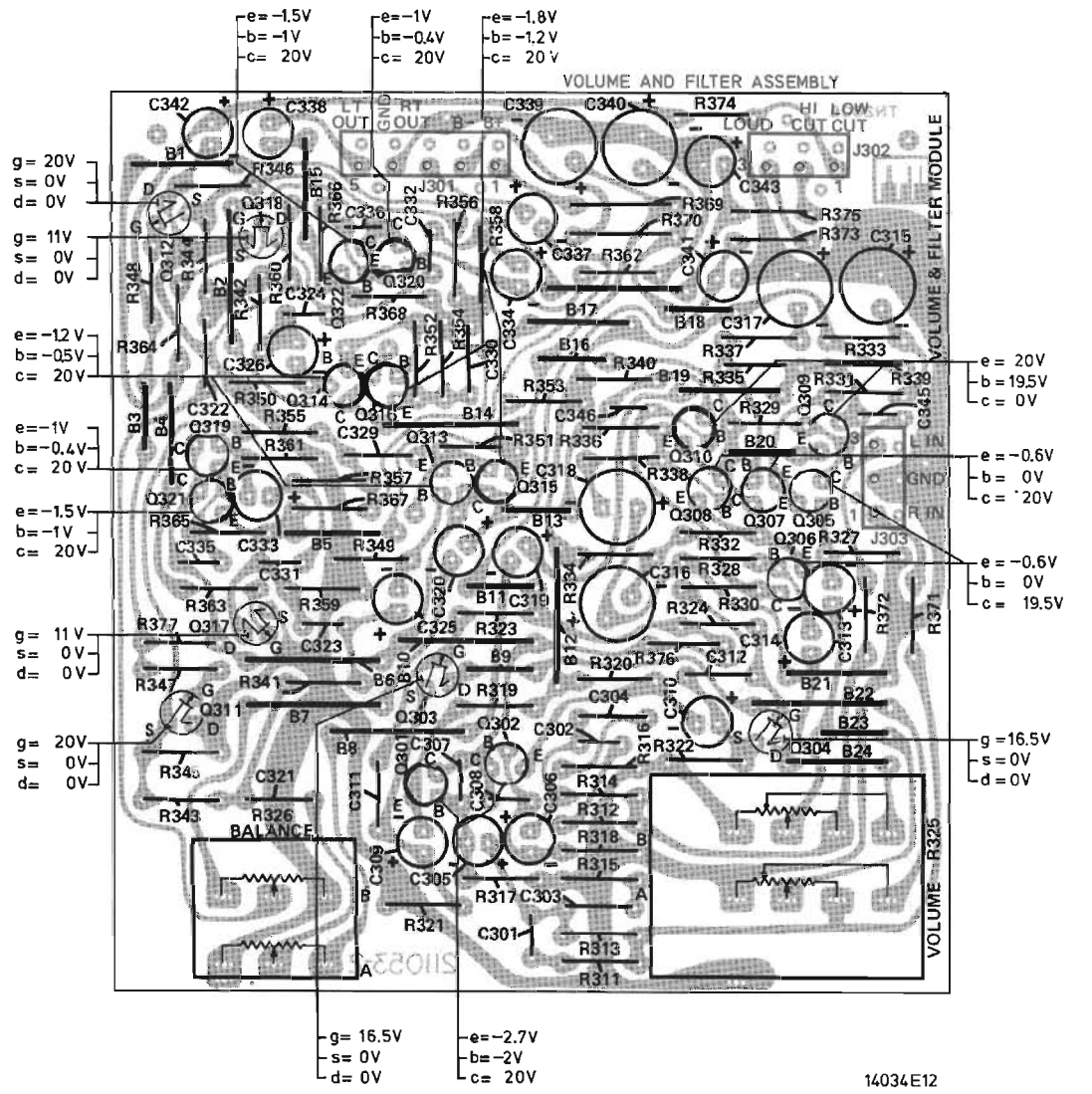
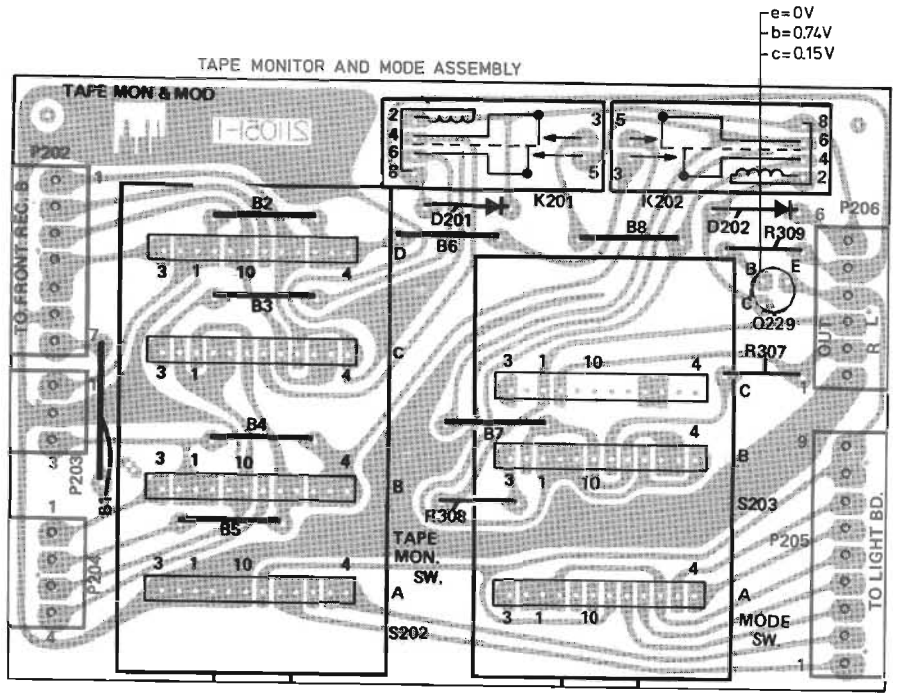
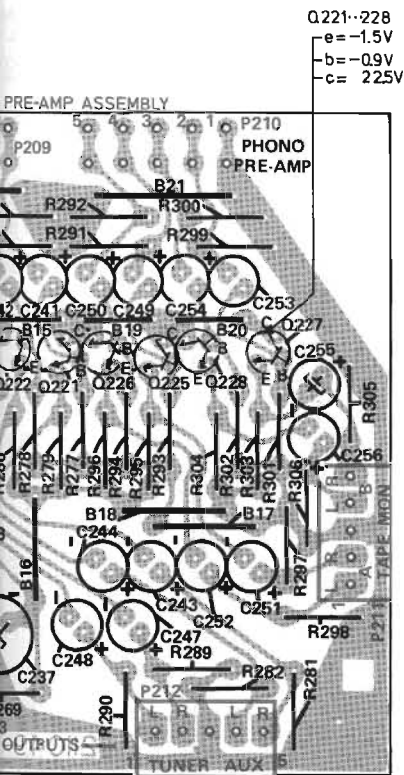
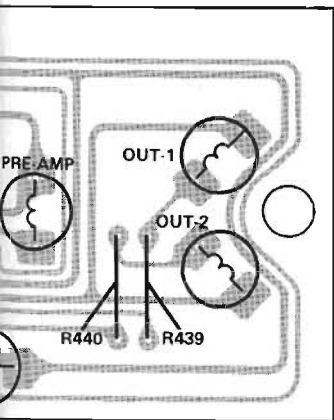
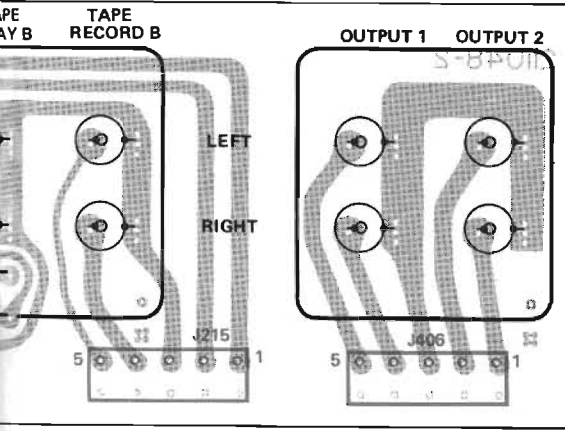

Fig. 8

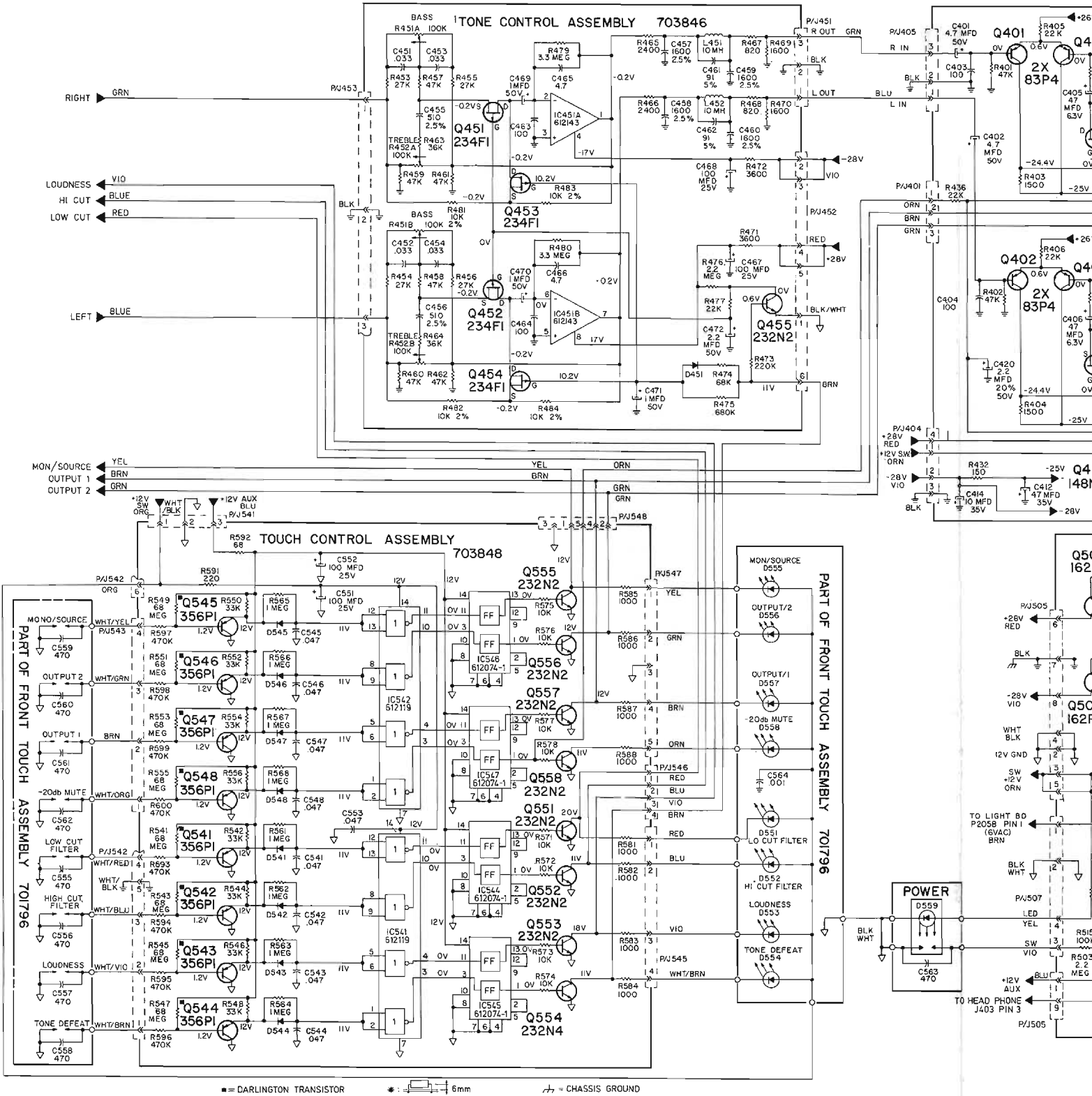

Fig. 9

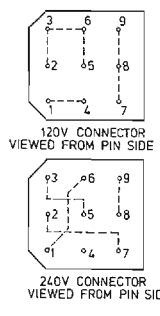
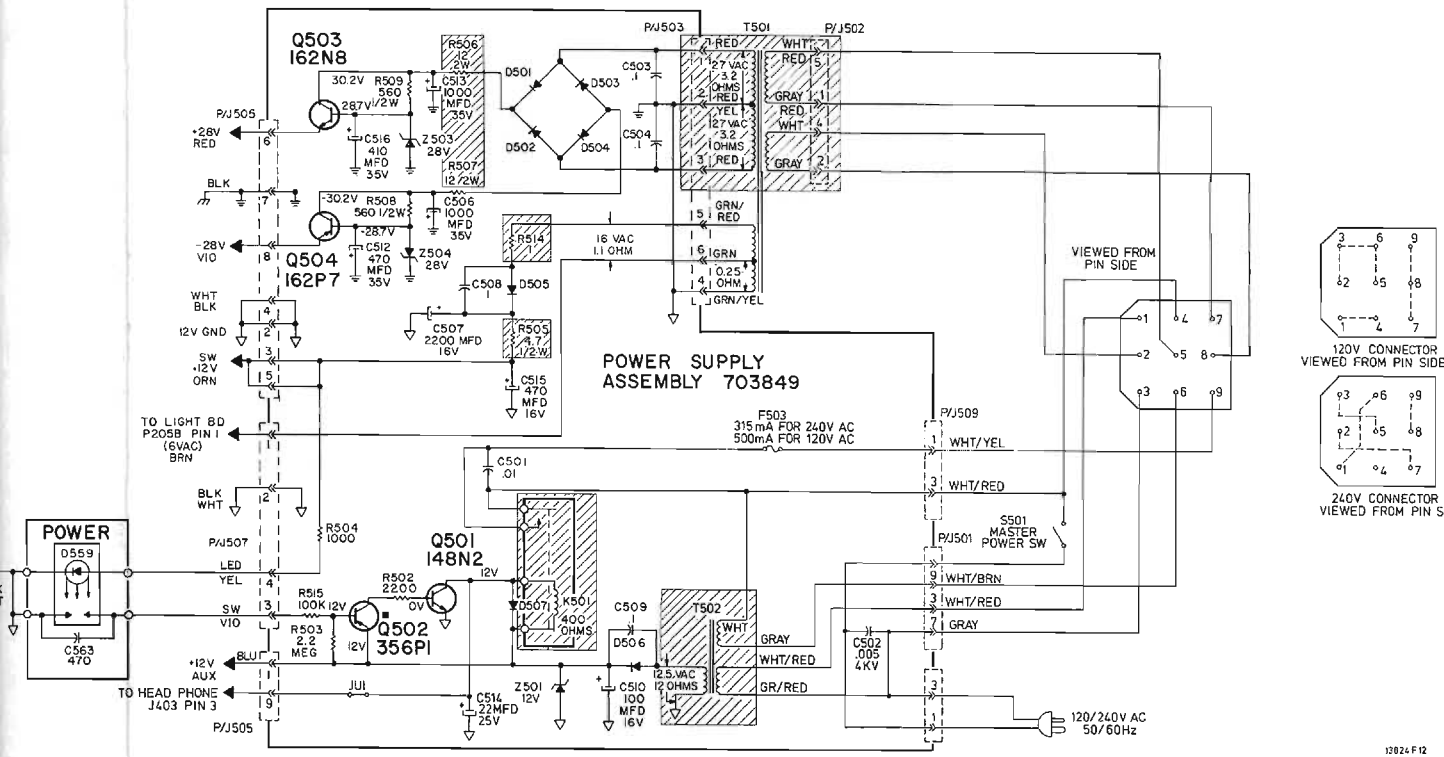
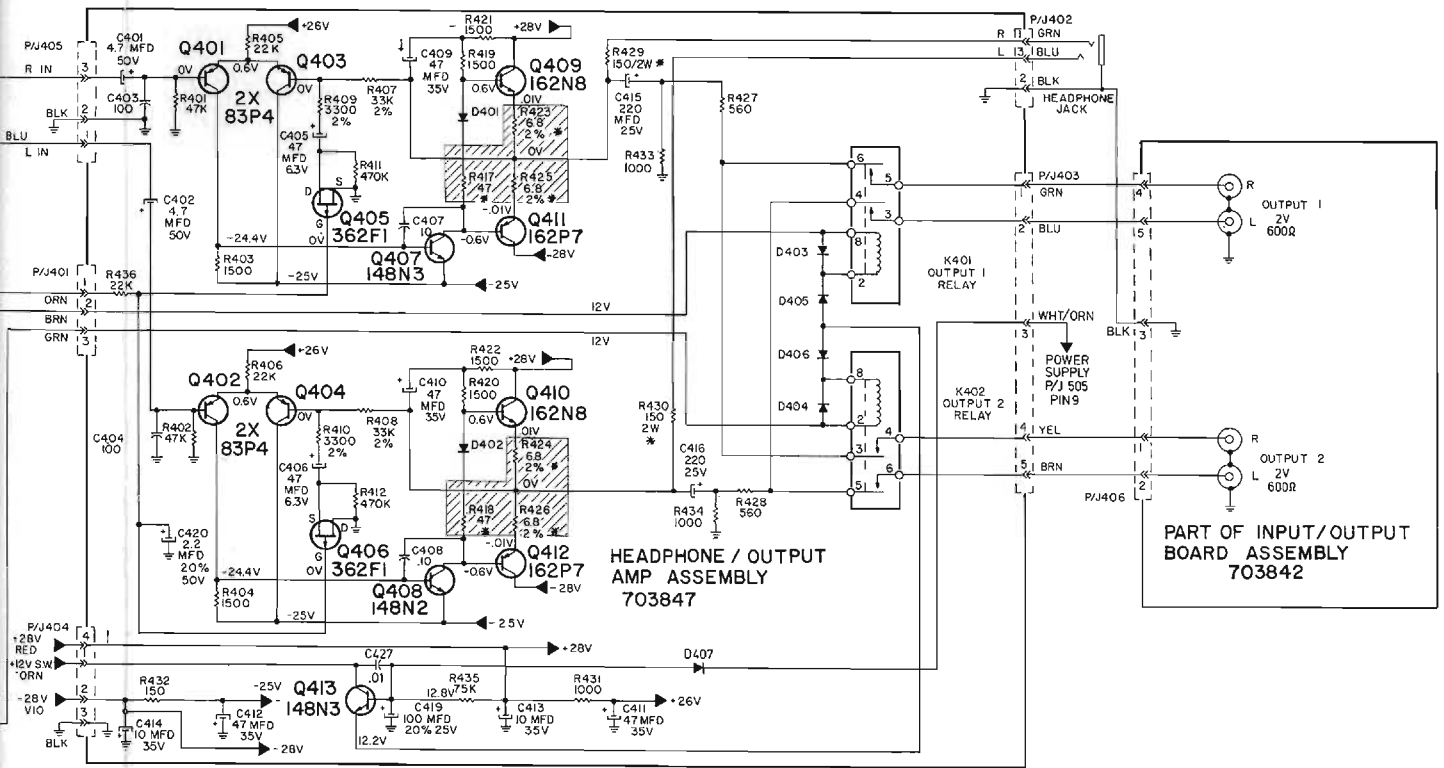
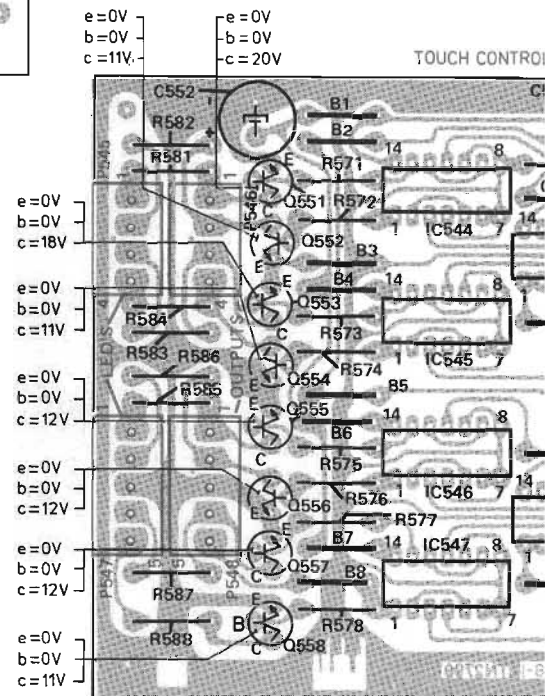
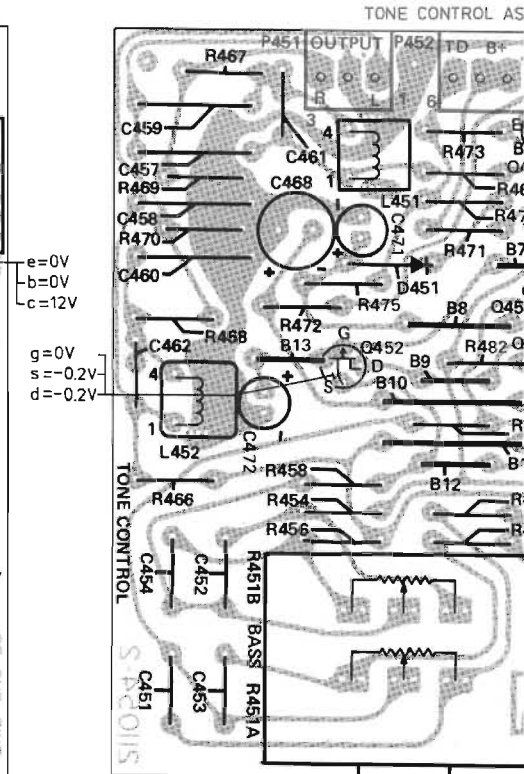
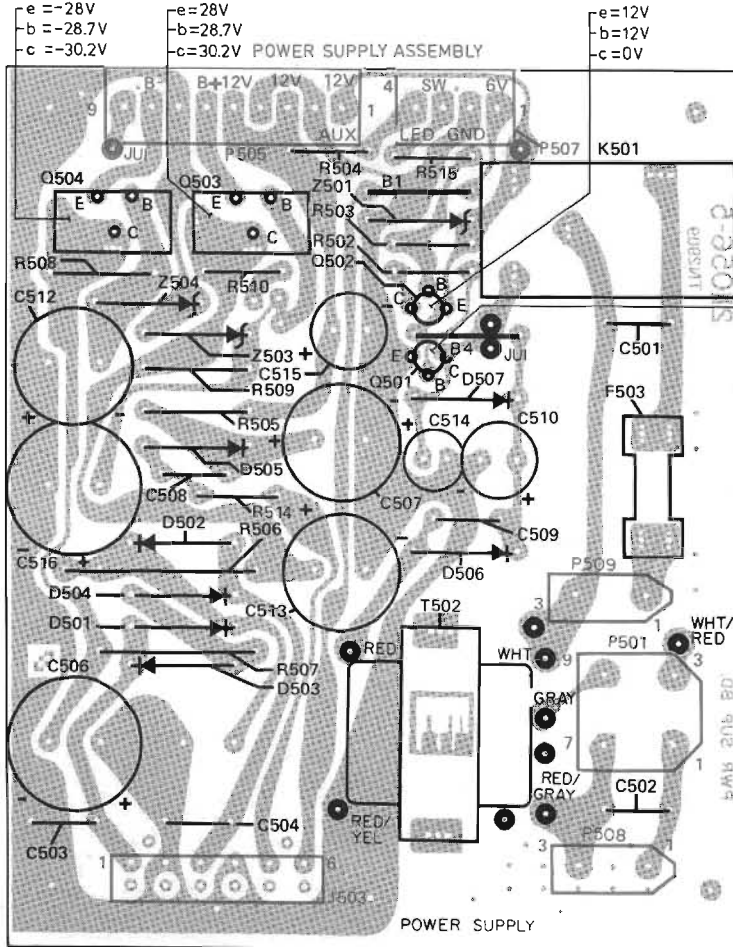
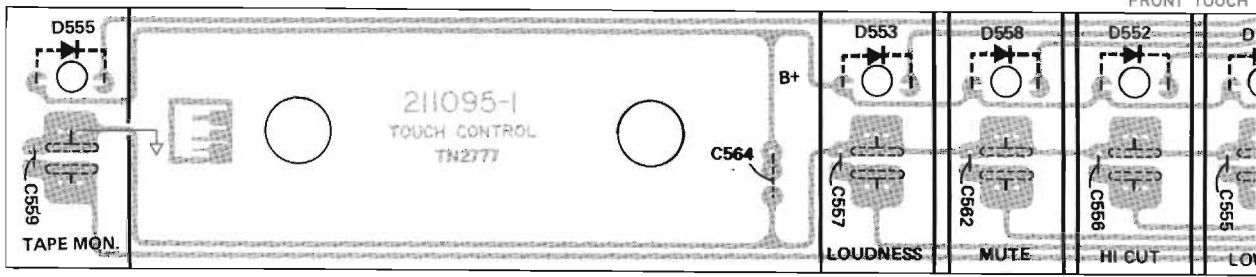

Fig. 9



HEADPHONE/PRE AMP

Q401...404	83P4	4822 130 41183
Q405-406	FET 362F1	4822 130 41192
Q407-408	148N3	4822 130 41186
Q409-410	162N8	4822 130 41188
Q411-412	162P7	4822 130 41187
Q413	148N2	4822 130 41185
D401...407		4822 130 30998
C401-402	4.7 μ F - 50 V	4822 134 20494
C405-406	47 μ F - 6.3 V	4822 124 20461
C409...412	47 μ F - 35 V	4822 124 20487
C413-414	10 μ F - 35 V	5322 124 24094
C415-416	220 μ F - 25 V	4822 124 20526
C419	100 μ F - 25 V	4822 124 20587
C420	2.2 μ F - 50 V	4822 124 20584
R409-419	3.3K-2% -1/4 W	5322 116 54005
R417-418	47 Ω -5% -1/4 W	4822 110 53072
R423...426	6.8 Ω -2% -1/4 W	4822 116 51172
R429-430	150 Ω -10% - 2 W	5322 116 54393
		5322 116 54393
-Miscellaneous-		
K401-402		4822 280 20068

POWER SUPPLY

Q501	148N2	4822 130 41185
Q502	356P1	4822 130 41191
Q503	162N8	4822 130 41188
Q504	162P7	4822 130 41187
D501...507		4822 130 30997
Z501	Zener 12 V -1/2 W	5322 130 34197
Z503-504	Zener 28 V -1/2 W	4822 130 30996
C501-502	5 nF+80%-20% 4KV	5322 122 50001
C503-504	100 nF 20 %-200 V	4822 121 41161
C508-509		
C506-513	1000 μ F - 35 V	5322 124 24067
C507	2200 μ F - 16 V	5322 124 24084
C510	100 μ F - 16 V	4822 124 20488
C512-515-516	470 μ F - 35 V	4822 124 20533
C514	22 μ F - 25 V	4822 124 20476
R505	4.7 Ω -5% -1/2 W	4822 110 43045
R506-507	12 Ω -5% -2 W	4822 112 41056
R514	1 Ω -5% -1/4 W	4822 110 53027
-Miscellaneous-		
T502		4822 145 30205
K501		4822 280 60398

TOUCH CONTROL

-IC-		
IC541...542	RCA652	4822 209 80399
IC544...547	CD4013BCN	4822 209 10002
Q541...548	356P1	4822 130 41191
Q551...558	232N2	4822 130 41101
D541...548		4822 130 30998
C551-552	100 μ F - 25 V	4822 124 20587
TAPE MONITOR AND MODE		
Q229	232N2	4822 130 41101
D201-202		4822 130 30998
-Miscellaneous-		
K201-202		4822 280 20068
S202		4822 273 80176
S203		4822 273 80177

VOLUME AND FILTER

Q301-302		
305...308		
313...316	94N4	4822 130 41184
319...322		
Q303-304	FET 234F1	4822 130 41189
311-312		
Q309-310	83P4	4822 130 41183
Q317-318	FET 362F1	4822 130 41192
C305-306		
313-314		
325...334-343	1 μ F - 50 V	4822 124 20583
C309-310	10 μ F - 35 V	5322 124 24094
341-342		
C315...320	47 μ F - 25 V	4822 124 20477
C337-338	47 μ F - 6.3 V	4822 124 20461
C339-340	100 μ F - 25 V	4822 124 20587
R325a,b	100K	4822 102 90014
R326a,b	10K 20% -1/8 W	4822 102 30263
R335-336	10K 2% -1/4 W	5322 116 54619
R341-342		
357-358	4.7K 2% -1/4 W	5322 116 54008
R369-370	150 Ω 5% -1/2 W	4822 110 43085

PHONO PRE-AMP

Q201...208		
213...216	94N4	4822 130 41184
221...228		
Q209...212	83P4	4822 130 41183
217...220		

TONE CONTROL

-IC-		
IC451	RC4558P	4822 209 80401
Q451...454	FET 234F1	4822 130 41189
Q455	232N2	4822 130 41101
D451		4822 130 30995
L451-452	10 mH	4822 156 10439
C455-456	510 pF-2.5%-60 V	4822 121 50056
C457...460	1600 pF-2.5%-60 V	4822 121 50554
C465-466	4.7 pF-10%-500 V	4822 122 31189
C467-468	100 μ F - 25 V	4822 124 20587
C469...471	1 μ F - 50 V	4822 124 20583
C472	2.2 μ F - 50 V	4822 124 20584
R451a,b		
R452a,b	100K	4822 102 90014
R481...484	10K-2% -1/4 W	5322 116 54619

C201...204		
243-244		
251-252	10 μ F - 35 V	5322 124 24094
255-256		
C209...212	100 μ F - 10 V	4822 124 20462
C221...224	47 μ F - 16 V	4822 124 20477
C229...232	4.7 μ F - 50 V	4822 124 20494
C233...236	22 μ F - 25 V	4822 124 20476
C237...240	100 μ F - 25 V	4822 124 20587
C241-242		
245-246		
249-250	1 μ F - 50 V	4822 124 20583
253-254		
C213-214	1.8 nF 2.5%-60 V	5322 121 54044
C215-216	2 nF -2.5%-60 V	4822 121 50472
C217...220	6.8 nF 2.5%-60 V	4822 121 50538
R225...228	5K-1/4 W adjust	4822 101 30343
R229...232	36K 2% -1/4 W	5322 116 54662
R237...240	470K 2% -1/4 W	5322 116 54336
R269-270	150 Ω 5% -1/4 W	4822 110 53085
R271-272	220 Ω 5% -1/4 W	4822 110 53089

BASIC CHASSIS

T501		4822 146 40241
S501		4822 277 10426
D551...559	LED	4822 130 30999

FUNCTION SELECTOR

S201		4822 273 80175
------	--	----------------